

Sheet List			
Sheet Number	Sheet Name	Sheet Issue Date	Current Revision
000	COVER PLATE	25/11/24	
001	DEMOLISHED PLAN	25/11/24	
002	SITE PLAN	25/11/24	
003	GROUND FLOOR	25/11/24	
004	SECONDARY DWELLING GF	25/11/24	
005	FIRST FLOOR	25/11/24	
006	ROOF PLAN	25/11/24	
007	ELEVATION	25/11/24	
008	ELEVATION 2	25/11/24	
009	ELEVATION 3	25/11/24	
010	SECTION	25/11/24	
011	SHADOW DIAGRAM	25/11/24	
012	SUBDIVISION PLAN	25/11/24	
013	LANDSCAPE PLAN	25/11/24	
014	WINDOW/DOOR SCHEDULE	25/11/24	
015	MATERIAL FINISH	25/11/24	
016	NEIGHBOUR NOTIFICATION PLAN	25/11/24	
017	POOL PROFILE	25/11/24	
018	BASIX	25/11/24	

COMPLIANCE TABLE

Dual Occupancies	Requirement	Proposed
Subdivision	450 m2	600 m2
FSR	0.5:1	608.38:1220 = 0.49:1
Height Limit	9m maximum	<9m
Front Setback	5.5m GF 6.5m FF	6m GF 7m FF
Side setback	0.9m	0.9m
PPOS	80 m2	80 m2
Secondary Building		
Height Limit	3m	<3m
Side Setback	0.9m	0.9m
Rear setback	0.9m	1.9m

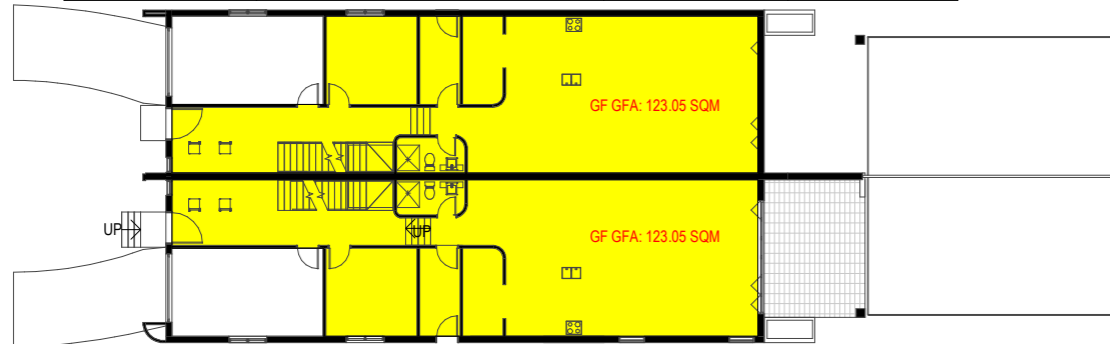

GF GFA

Scale1 : 300

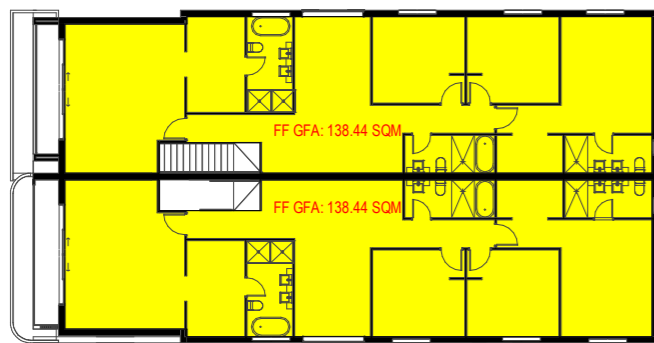

F.F GFA

Scale1 : 300

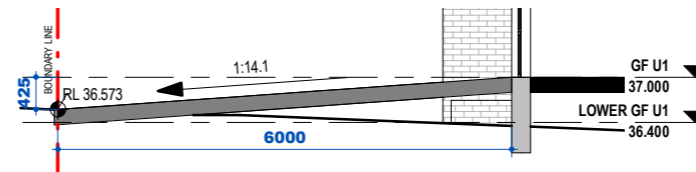
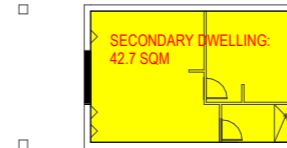
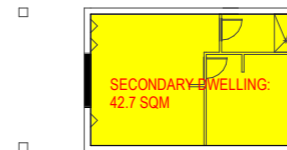

DRIVEWAY PROFILE U1

Scale 1 : 100

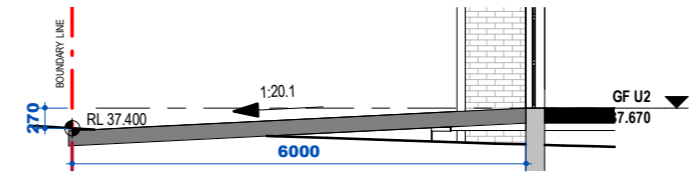

DRIVEWAY PROFILE U2

Scale 1 : 100

© COPYRIGHT

THIS DOCUMENT IS SUBJECT TO COPYRIGHT LAWS & MAY NOT BE COPIED IN PART OF WHOLE WITHOUT THE WRITTEN PERMISSION OF JMJ HOMES PTY LTD

NOTES:

1. ALL DIMENSIONS AND FLOOR AREAS TO BE VERIFIED PRIOR TO THE COMMENCEMENT OF ANY BUILDING WORK.
2. ANY DISCREPANCIES ARE TO BE CONFIRMED BY THE DESIGNER.
3. LEVELS SHOWN ARE APPROXIMATE UNLESS ACCOMPANIED BY REDUCED LEVELS BY A REGISTERED SURVEYOR.
4. FIGURED DIMENSIONS ARE TO BE TAKEN IN PREFERENCE TO SCALING.
5. ALL BOUNDARY CLEARANCE MUST BE VERIFIED BY THE SURVEYOR PRIOR TO THE COMMENCEMENT OF ANY BUILDING WORK.
6. WHERE ENGINEERING OR HYDRAULIC DRAWINGS ARE REQUIRED, SUCH MUST TAKE PREFERENCE TO THIS DRAWINGS.
7. ALL SERVICES TO BE LOCATED AND VERIFIED BY THE BUILDER PRIOR TO THE COMMENCEMENT OF ANY BUILDING WORK.

Issued for: DA
 Designed by: S.L
 Drawn by: S.L
 Checked by: R.B
 Issued Date: 25/11/24



Drawing Title
000
COVER PLATE
 SCALE@A3 As indicated

PROJECT TITLE:
29 Queensbury Road Padstow
Height
 CLIENTS:



52 Hall Street, Bondi Beach, NSW, 2026
 info@mjhomes.com.au
 0456 888 444

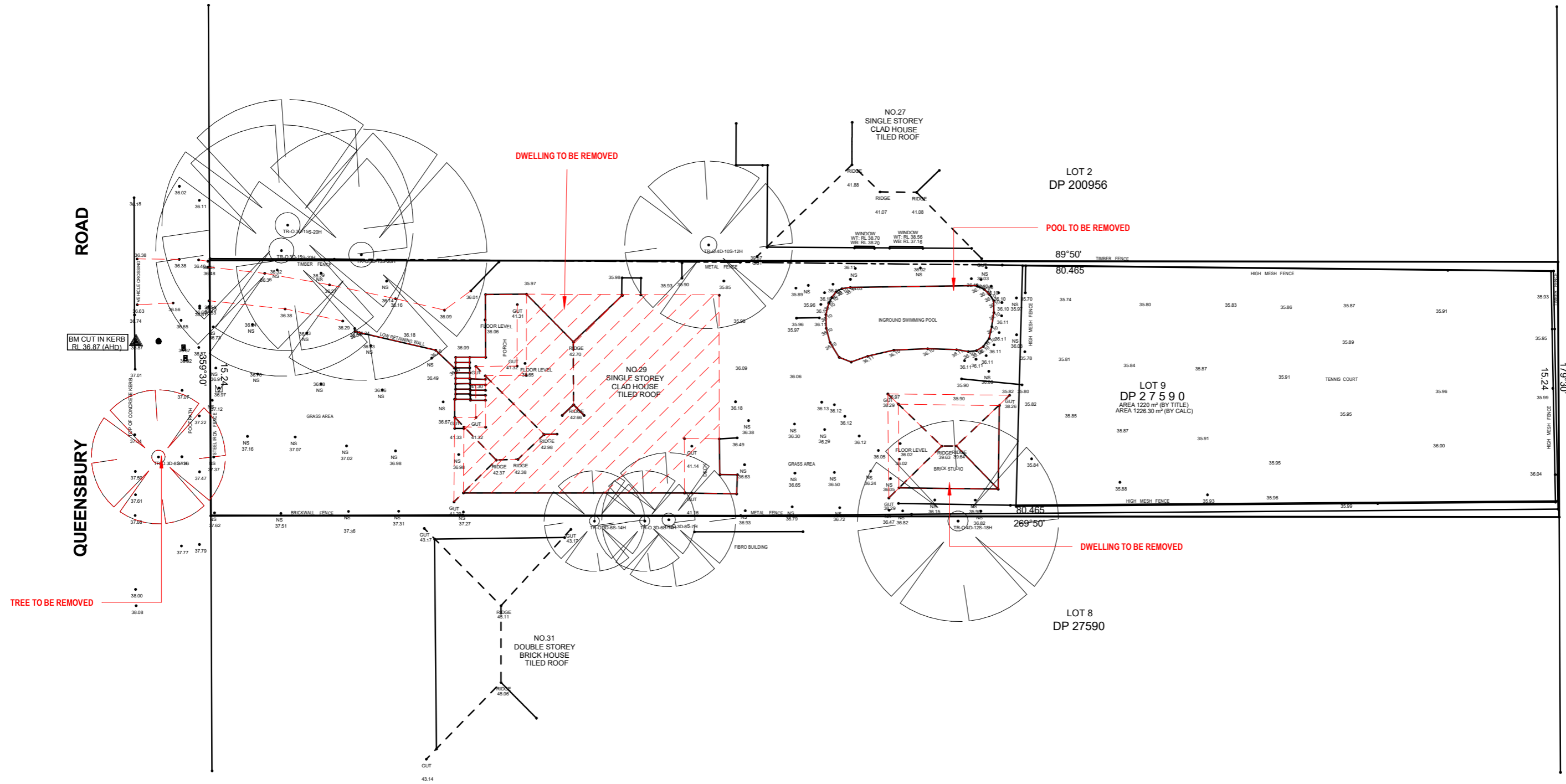

LOT 1
DP 200956

LOT 11
DP 1229424

LOT 10
DP 1229424

LOT 2
DP 200956

LOT 9
DP 27590
AREA 1220 m² (BY TITLE)
AREA 1226.30 m² (BY CALC)

LOT 8
DP 27590

© COPYRIGHT
THIS DOCUMENT IS SUBJECT TO
COPYRIGHT LAWS & MAY NOT BE COPIED
IN PART OF WHOLE WITHOUT THE
WRITTEN PERMISSION OF JMJ HOMES
PTY LTD

NOTES:
1. ALL DIMENSIONS AND FLOOR AREAS TO BE VERIFIED PRIOR TO THE COMMENCEMENT OF ANY BUILDING WORK.
2. ANY DISCREPANCIES ARE TO BE CONFIRMED BY THE DESIGNER.
3. LEVELS SHOWN ARE APPROXIMATE UNLESS ACCOMPANIED BY REDUCED LEVELS BY A REGISTERED SURVEYOR.
4. FIGURED DIMENSIONS ARE TO BE TAKEN IN PREFERENCE TO SCALING.
5. ALL BOUNDARY CLEARANCE MUST BE VERIFIED BY THE SURVEYOR PRIOR TO THE COMMENCEMENT OF ANY BUILDING WORK.
6. WHERE ENGINEERING OR HYDRAULIC DRAWINGS ARE REQUIRED, SUCH MUST TAKE PREFERENCE TO THIS DRAWINGS.
7. ALL SERVICES TO BE LOCATED AND VERIFIED BY THE BUILDER PRIOR TO THE COMMENCEMENT OF ANY BUILDING WORK.

Issued for: DA
Designed by: S.L
Drawn by: S.L
Checked by: R.B
Issued Date: 25/11/24



Drawing Title
**001
DEMOLISHED PLAN**
SCALE@A3 1 : 250

PROJECT TITLE:
**29 Queensbury Road Padstow
Height**
CLIENTS:



52 Hall Street, Bondi Beach, NSW, 2026
info@mjhomes.com.au
0456 888 444

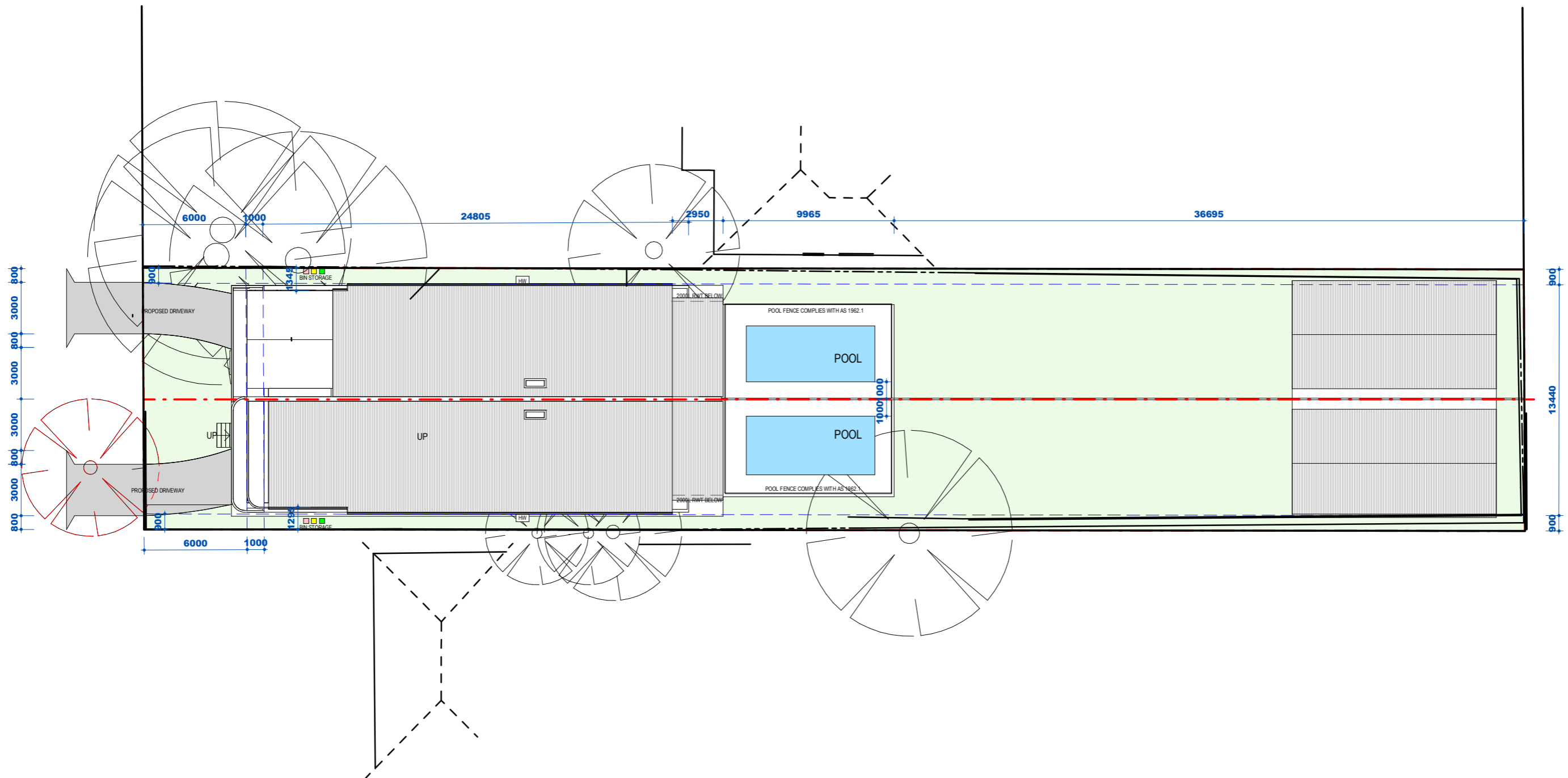

SITE PLAN

Scale 1 : 250

<p>© COPYRIGHT THIS DOCUMENT IS SUBJECT TO COPYRIGHT LAWS & MAY NOT BE COPIED IN PART OF WHOLE WITHOUT THE WRITTEN PERMISSION OF JMJ HOMES PTY LTD</p>	<p>NOTES: 1. ALL DIMENSIONS AND FLOOR AREAS TO BE VERIFIED PRIOR TO THE COMMENCEMENT OF ANY BUILDING WORK. 2. ANY DISCREPANCIES ARE TO BE CONFIRMED BY THE DESIGNER. 3. LEVELS SHOWN ARE APPROXIMATE UNLESS ACCOMPANIED BY REDUCED LEVELS BY A REGISTERED SURVEYOR. 4. FIGURED DIMENSIONS ARE TO BE TAKEN IN PREFERENCE TO SCALING. 5. ALL BOUNDARY CLEARANCE MUST BE VERIFIED BY THE SURVEYOR PRIOR TO THE COMMENCEMENT OF ANY BUILDING WORK. 6. WHERE ENGINEERING OR HYDRAULIC DRAWINGS ARE REQUIRED, SUCH MUST TAKE PREFERENCE TO THIS DRAWINGS. 7. ALL SERVICES TO BE LOCATED AND VERIFIED BY THE BUILDER PRIOR TO THE COMMENCEMENT OF ANY BUILDING WORK.</p>	<p>Issued for: DA Designed by: S.L Drawn by: S.L Checked by: R.B Issued Date: 25/11/24</p>	<p>TRUE NORTH</p>	<p>Drawing Title 002 SITE PLAN SCALE@A3 1 : 250</p>	<p>PROJECT TITLE: 29 Queensbury Road Padstow Height CLIENTS:</p>	<p>JMJ HOMES 52 Hall Street, Bondi Beach, NSW, 2026 info@mjhomes.com.au 0456 888 444</p>
--	--	--	-------------------	---	--	---

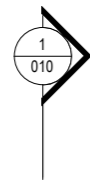

008
2
Elevation 2 - a
23740

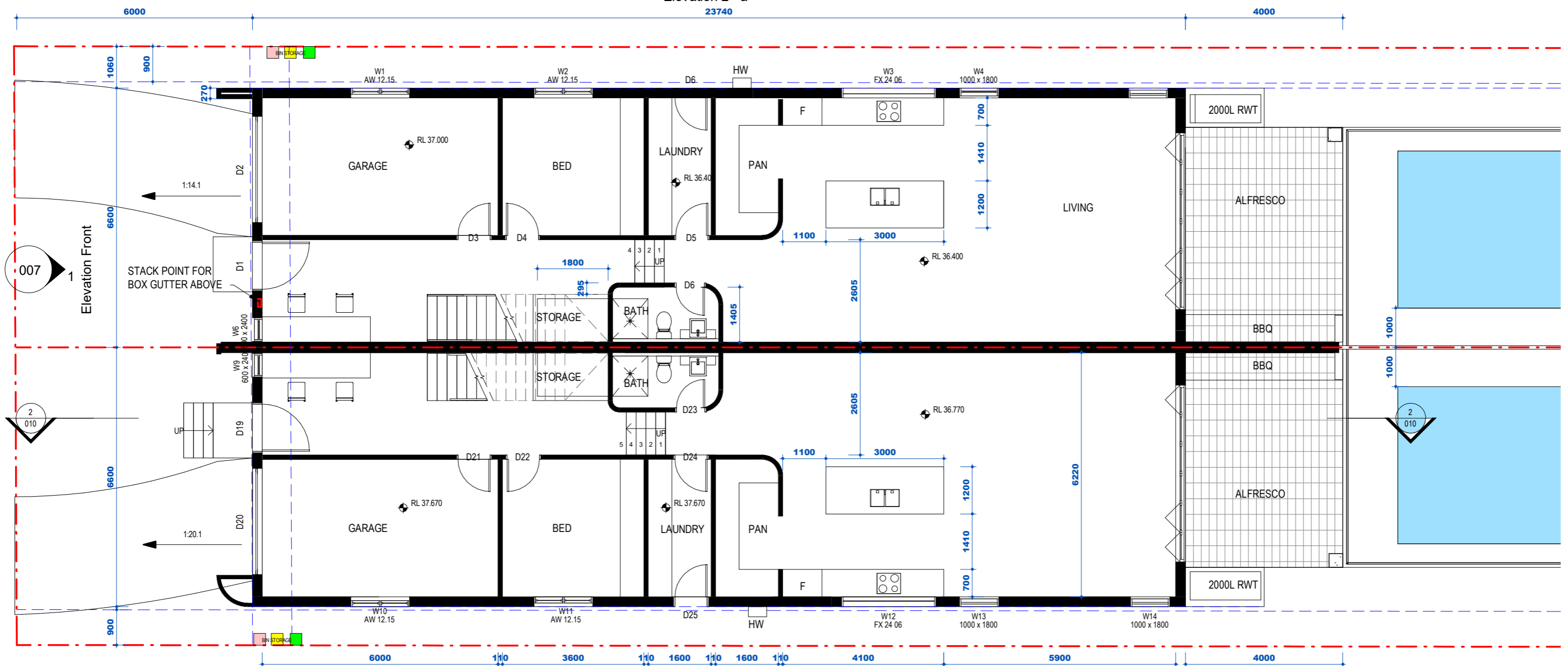

Elevation 1 - a
1
008

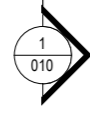

NOTES:
HW: HOT WATER SYSTEM - HEAT PUMP - 31 TP 35 STC REFER TO BASIX
RWT: MIN 2000L RAINWATER TANK REFER TO BASIX

GROUND FLOOR
Scale 1 : 100

© COPYRIGHT
THIS DOCUMENT IS SUBJECT TO
COPYRIGHT LAWS & MAY NOT BE COPIED
IN PART OF WHOLE WITHOUT THE
WRITTEN PERMISSION OF JMJ HOMES
PTY LTD

NOTES:
1. ALL DIMENSIONS AND FLOOR AREAS TO BE VERIFIED PRIOR TO THE COMMENCEMENT OF ANY BUILDING WORK.
2. ANY DISCREPANCIES ARE TO BE CONFIRMED BY THE DESIGNER.
3. LEVELS SHOWN ARE APPROXIMATE UNLESS ACCOMPANIED BY REDUCED LEVELS BY A REGISTERED SURVEYOR.
4. FIGURED DIMENSIONS ARE TO BE TAKEN IN PREFERENCE TO SCALING.
5. ALL BOUNDARY CLEARANCE MUST BE VERIFIED BY THE SURVEYOR PRIOR TO THE COMMENCEMENT OF ANY BUILDING WORK.
6. WHERE ENGINEERING OR HYDRAULIC DRAWINGS ARE REQUIRED, SUCH MUST TAKE PREFERENCE TO THIS DRAWINGS.
7. ALL SERVICES TO BE LOCATED AND VERIFIED BY THE BUILDER PRIOR TO THE COMMENCEMENT OF ANY BUILDING WORK.

Issued for: DA
Designed by: S.L
Drawn by: S.L
Checked by: R.B
Issued Date: 25/11/24



Drawing Title
003
GROUND FLOOR
SCALE@A3 1 : 100

PROJECT TITLE:
**29 Queensbury Road Padstow
Height**
CLIENTS:

JMJ HOMES
52 Hall Street, Bondi Beach, NSW, 2026
info@mjhomes.com.au
0456 888 444

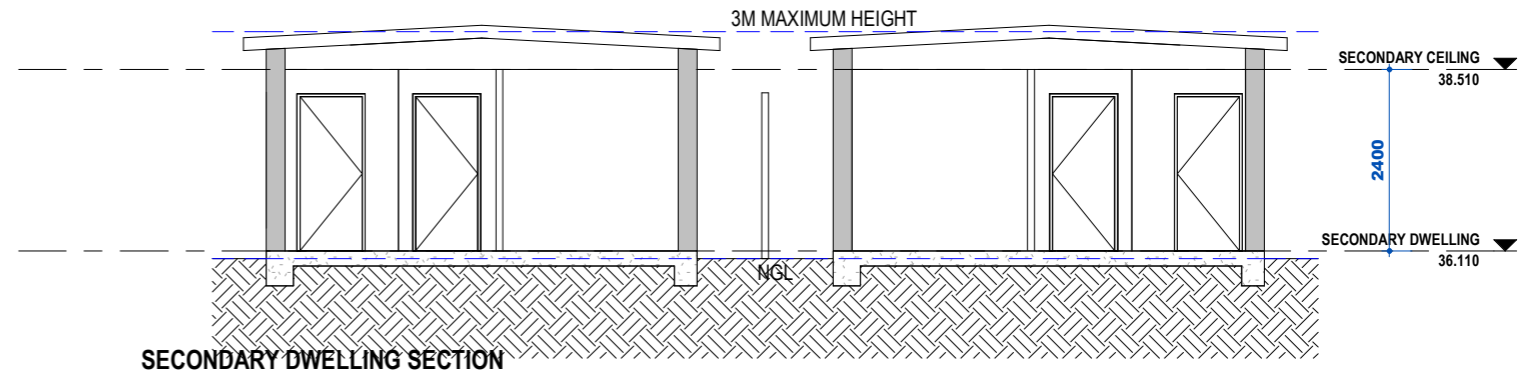
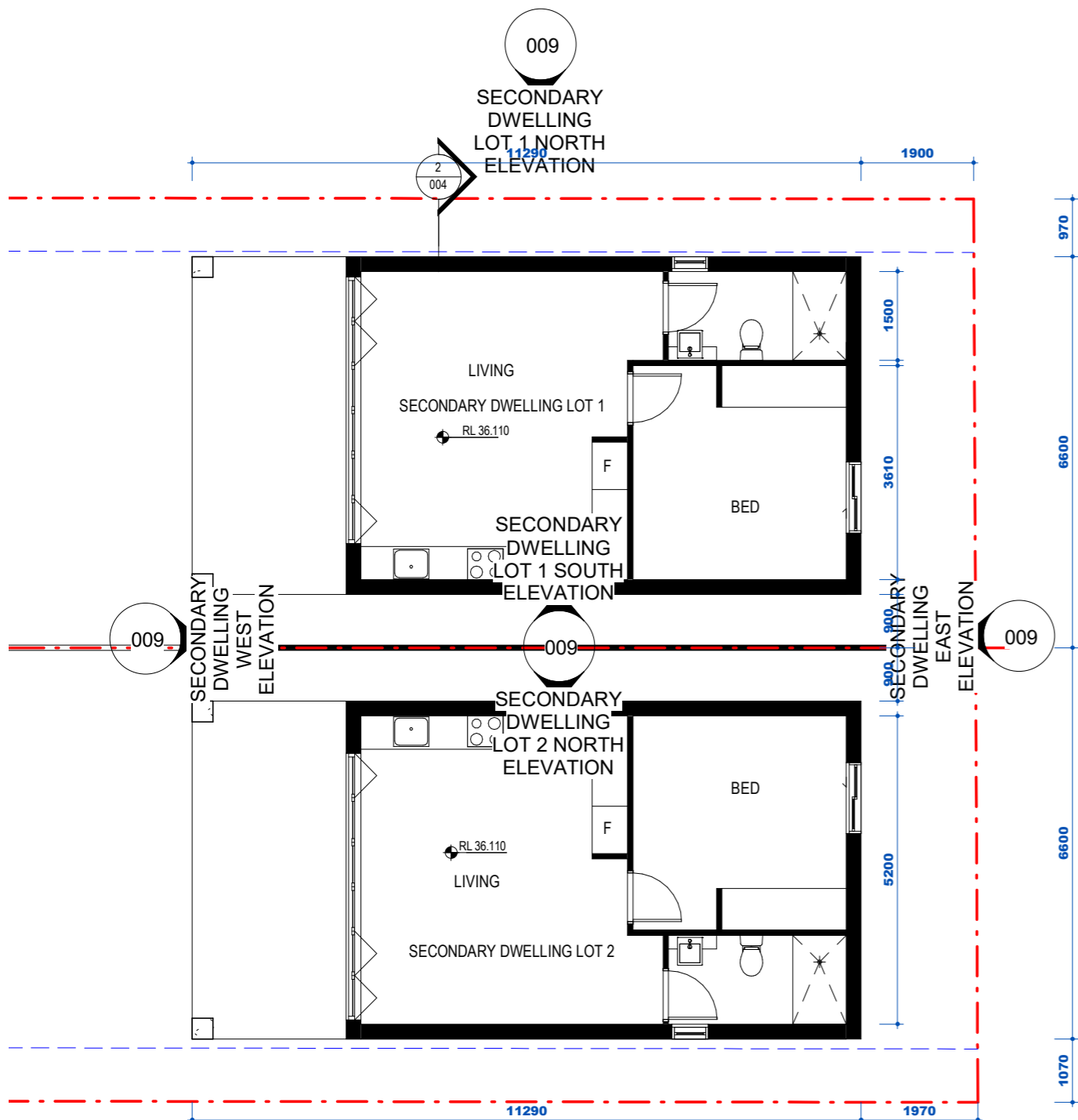

SECONDARY DWELLING SECTION
Scale 1 : 100

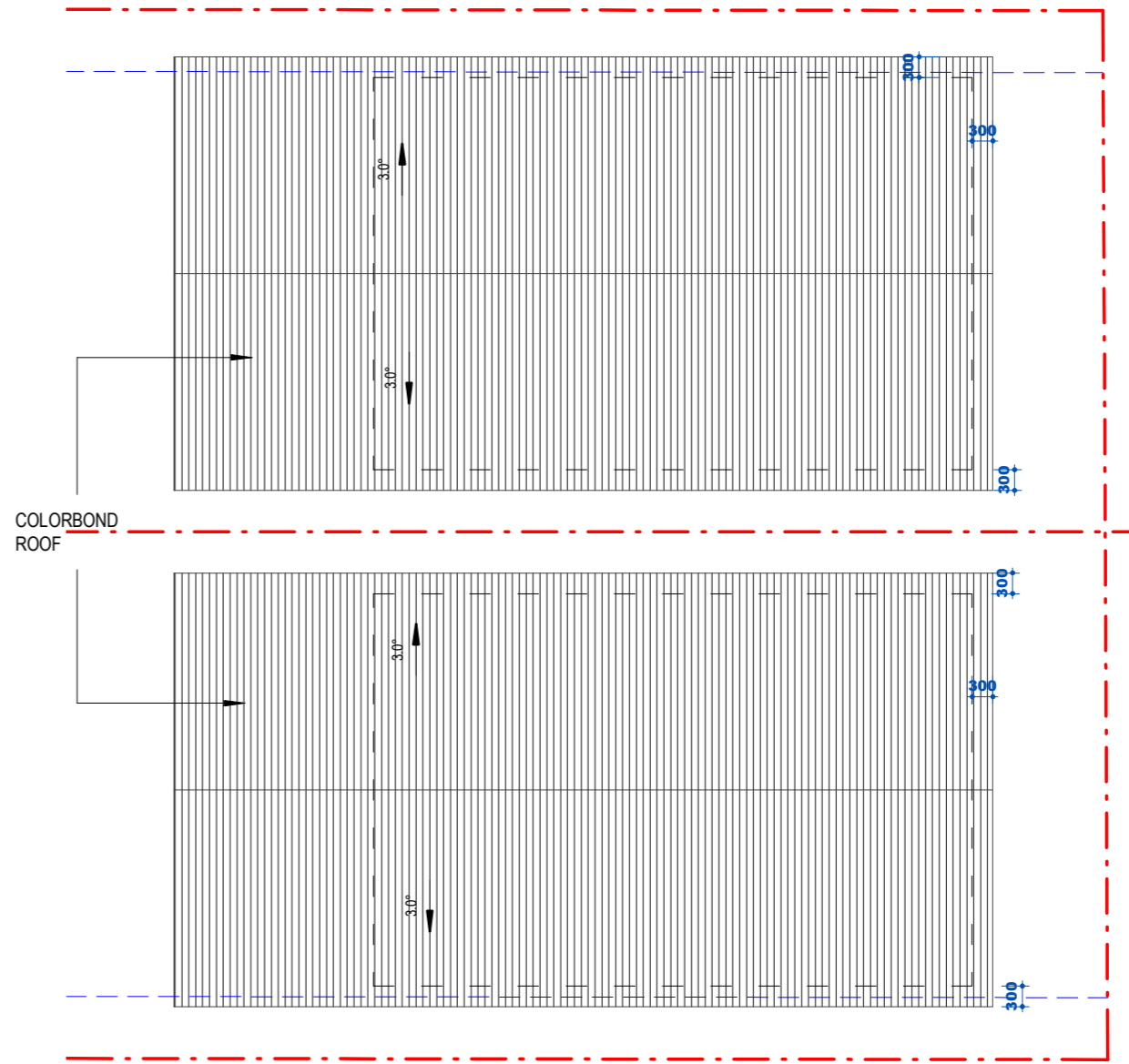

SECONDARY DWELLING ROOF
Scale 1 : 100

SECONDARY DWELLING
Scale 1 : 100

© COPYRIGHT
THIS DOCUMENT IS SUBJECT TO COPYRIGHT LAWS & MAY NOT BE COPIED IN PART OF WHOLE WITHOUT THE WRITTEN PERMISSION OF JMJ HOMES PTY LTD

- NOTES:**
1. ALL DIMENSIONS AND FLOOR AREAS TO BE VERIFIED PRIOR TO THE COMMENCEMENT OF ANY BUILDING WORK.
 2. ANY DISCREPANCIES ARE TO BE CONFIRMED BY THE DESIGNER.
 3. LEVELS SHOWN ARE APPROXIMATE UNLESS ACCOMPANIED BY REDUCED LEVELS BY A REGISTERED SURVEYOR.
 4. FIGURED DIMENSIONS ARE TO BE TAKEN IN PREFERENCE TO SCALING.
 5. ALL BOUNDARY CLEARANCE MUST BE VERIFIED BY THE SURVEYOR PRIOR TO THE COMMENCEMENT OF ANY BUILDING WORK.
 6. WHERE ENGINEERING OR HYDRAULIC DRAWINGS ARE REQUIRED, SUCH MUST TAKE PREFERENCE TO THIS DRAWINGS.
 7. ALL SERVICES TO BE LOCATED AND VERIFIED BY THE BUILDER PRIOR TO THE COMMENCEMENT OF ANY BUILDING WORK.

Issued for: DA
Designed by: S.L
Drawn by: S.L
Checked by: R.B
Issued Date: 25/11/24



Drawing Title
004 SECONDARY DWELLING GF
SCALE@A3 1 : 100

PROJECT TITLE:
29 Queensbury Road Padstow Height
CLIENTS:

52 Hall Street, Bondi Beach, NSW, 2026
info@mjhomes.com.au
0456 888 444



FIRST FLOOR PLAN

Scale 1 : 100

© COPYRIGHT

THIS DOCUMENT IS SUBJECT TO COPYRIGHT LAWS & MAY NOT BE COPIED IN PART OF WHOLE WITHOUT THE WRITTEN PERMISSION OF JMJ HOMES PTY LTD

NOTES:

1. ALL DIMENSIONS AND FLOOR AREAS TO BE VERIFIED PRIOR TO THE COMMENCEMENT OF ANY BUILDING WORK.
2. ANY DISCREPANCIES ARE TO BE CONFIRMED BY THE DESIGNER.
3. LEVELS SHOWN ARE APPROXIMATE UNLESS ACCOMPANIED BY REDUCED LEVELS BY A REGISTERED SURVEYOR.
4. FIGURED DIMENSIONS ARE TO BE TAKEN IN PREFERENCE TO SCALING.
5. ALL BOUNDARY CLEARANCE MUST BE VERIFIED BY THE SURVEYOR PRIOR TO THE COMMENCEMENT OF ANY BUILDING WORK.
6. WHERE ENGINEERING OR HYDRAULIC DRAWINGS ARE REQUIRED, SUCH MUST TAKE PREFERENCE TO THIS DRAWINGS.
7. ALL SERVICES TO BE LOCATED AND VERIFIED BY THE BUILDER PRIOR TO THE COMMENCEMENT OF ANY BUILDING WORK.

Issued for: DA
 Designed by: S.L
 Drawn by: S.L
 Checked by: R.B
 Issued Date: 25/11/24



TRUE NORTH

Drawing Title
005
FIRST FLOOR
 SCALE@A3 1 : 100

PROJECT TITLE:
29 Queensbury Road Padstow
Height
 CLIENTS:



52 Hall Street, Bondi Beach, NSW, 2026
 info@mjhomes.com.au
 0456 888 444

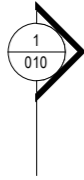

008
2
Elevation 2 - a

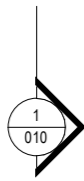
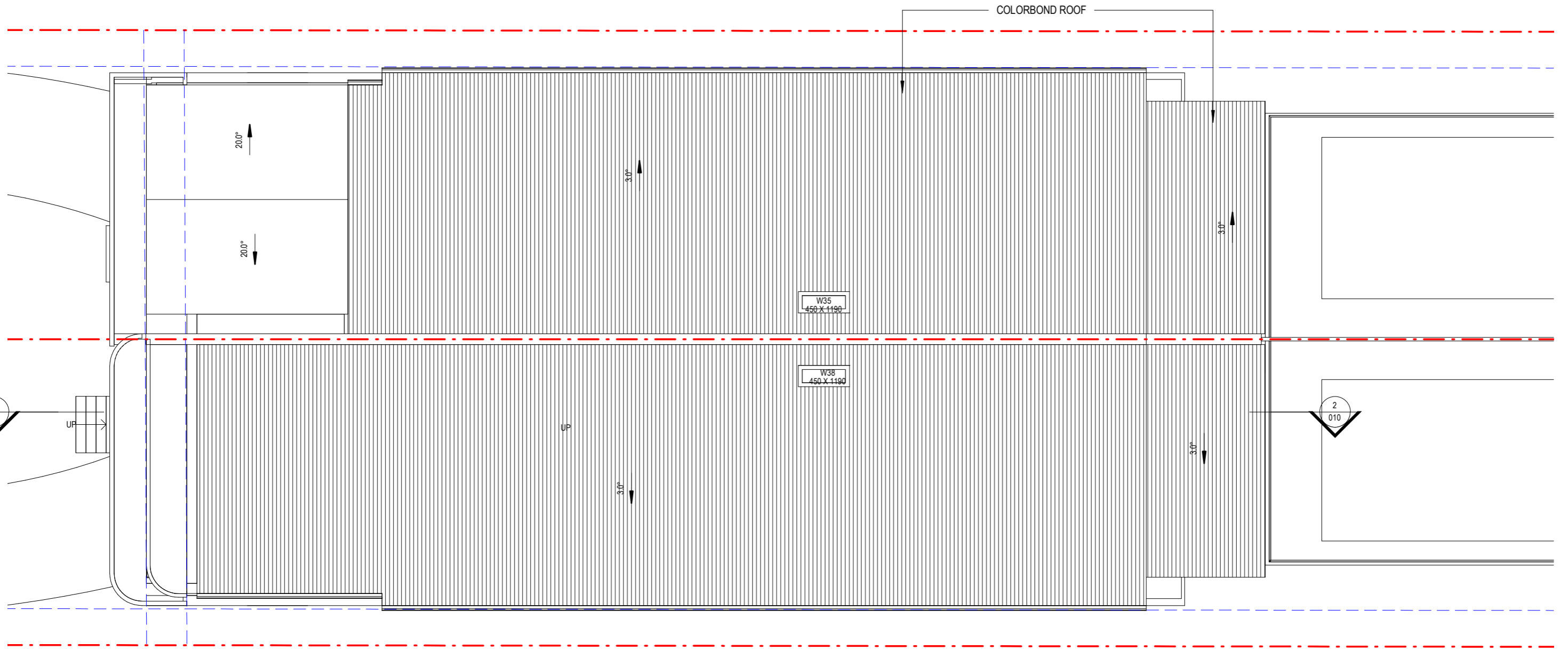

Elevation 1 - a
1
008

ROOF PLAN
Scale 1 : 100

© COPYRIGHT

THIS DOCUMENT IS SUBJECT TO COPYRIGHT LAWS & MAY NOT BE COPIED IN PART OF WHOLE WITHOUT THE WRITTEN PERMISSION OF JMJ HOMES PTY LTD

NOTES:

1. ALL DIMENSIONS AND FLOOR AREAS TO BE VERIFIED PRIOR TO THE COMMENCEMENT OF ANY BUILDING WORK.
2. ANY DISCREPANCIES ARE TO BE CONFIRMED BY THE DESIGNER.
3. LEVELS SHOWN ARE APPROXIMATE UNLESS ACCOMPANIED BY REDUCED LEVELS BY A REGISTERED SURVEYOR.
4. FIGURED DIMENSIONS ARE TO BE TAKEN IN PREFERENCE TO SCALING.
5. ALL BOUNDARY CLEARANCE MUST BE VERIFIED BY THE SURVEYOR PRIOR TO THE COMMENCEMENT OF ANY BUILDING WORK.
6. WHERE ENGINEERING OR HYDRAULIC DRAWINGS ARE REQUIRED, SUCH MUST TAKE PREFERENCE TO THIS DRAWINGS.
7. ALL SERVICES TO BE LOCATED AND VERIFIED BY THE BUILDER PRIOR TO THE COMMENCEMENT OF ANY BUILDING WORK.

Issued for: DA
 Designed by: S.L
 Drawn by: S.L
 Checked by: R.B
 Issued Date: 25/11/24



TRUE NORTH

Drawing Title
006
ROOF PLAN

SCALE@A3 1 : 100

PROJECT TITLE:
29 Queensbury Road Padstow
Height

CLIENTS:



52 Hall Street, Bondi Beach, NSW, 2026
 info@mjhomes.com.au
 0456 888 444

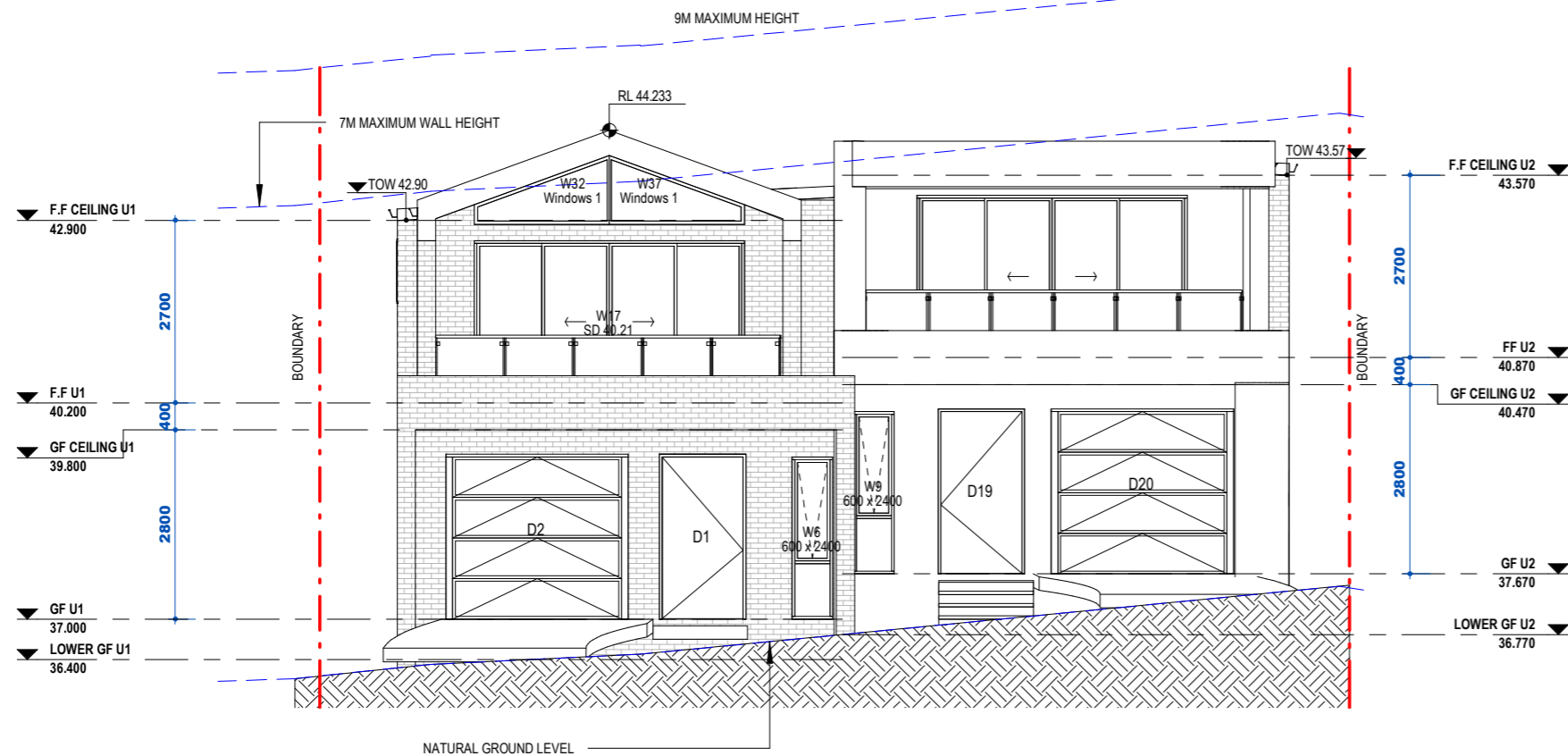

Elevation Front

Scale 1 : 100

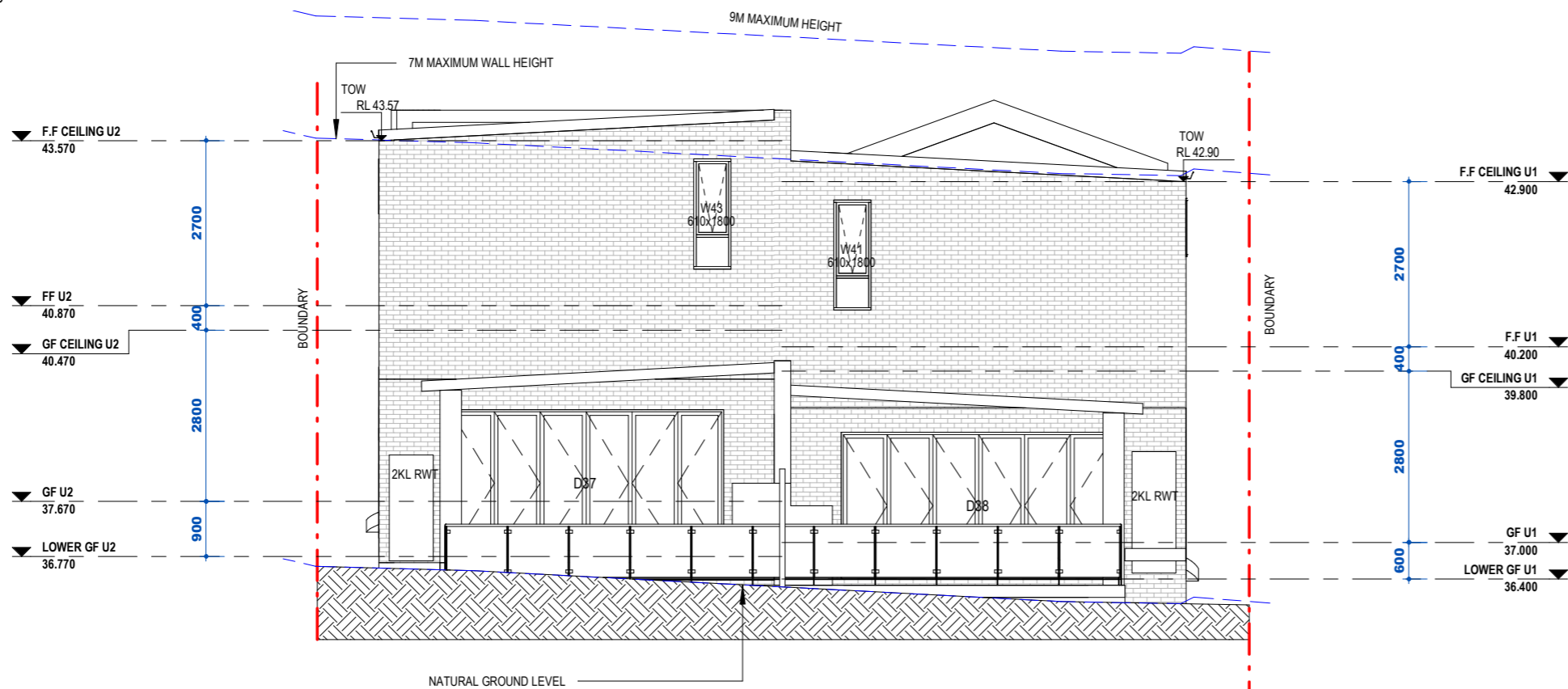

Elevation Rear

Scale 1 : 100

© COPYRIGHT

THIS DOCUMENT IS SUBJECT TO COPYRIGHT LAWS & MAY NOT BE COPIED IN PART OF WHOLE WITHOUT THE WRITTEN PERMISSION OF JMJ HOMES PTY LTD

NOTES:

1. ALL DIMENSIONS AND FLOOR AREAS TO BE VERIFIED PRIOR TO THE COMMENCEMENT OF ANY BUILDING WORK.
2. ANY DISCREPANCIES ARE TO BE CONFIRMED BY THE DESIGNER.
3. LEVELS SHOWN ARE APPROXIMATE UNLESS ACCOMPANIED BY REDUCED LEVELS BY A REGISTERED SURVEYOR.
4. FIGURED DIMENSIONS ARE TO BE TAKEN IN PREFERENCE TO SCALING.
5. ALL BOUNDARY CLEARANCE MUST BE VERIFIED BY THE SURVEYOR PRIOR TO THE COMMENCEMENT OF ANY BUILDING WORK.
6. WHERE ENGINEERING OR HYDRAULIC DRAWINGS ARE REQUIRED, SUCH MUST TAKE PREFERENCE TO THIS DRAWINGS.
7. ALL SERVICES TO BE LOCATED AND VERIFIED BY THE BUILDER PRIOR TO THE COMMENCEMENT OF ANY BUILDING WORK.

Issued for: DA
 Designed by: S.L
 Drawn by: S.L
 Checked by: R.B
 Issued Date: 25/11/24



Drawing Title
007
ELEVATION

SCALE@A3 1 : 100



PROJECT TITLE:
29 Queensbury Road Padstow
Height

CLIENTS:

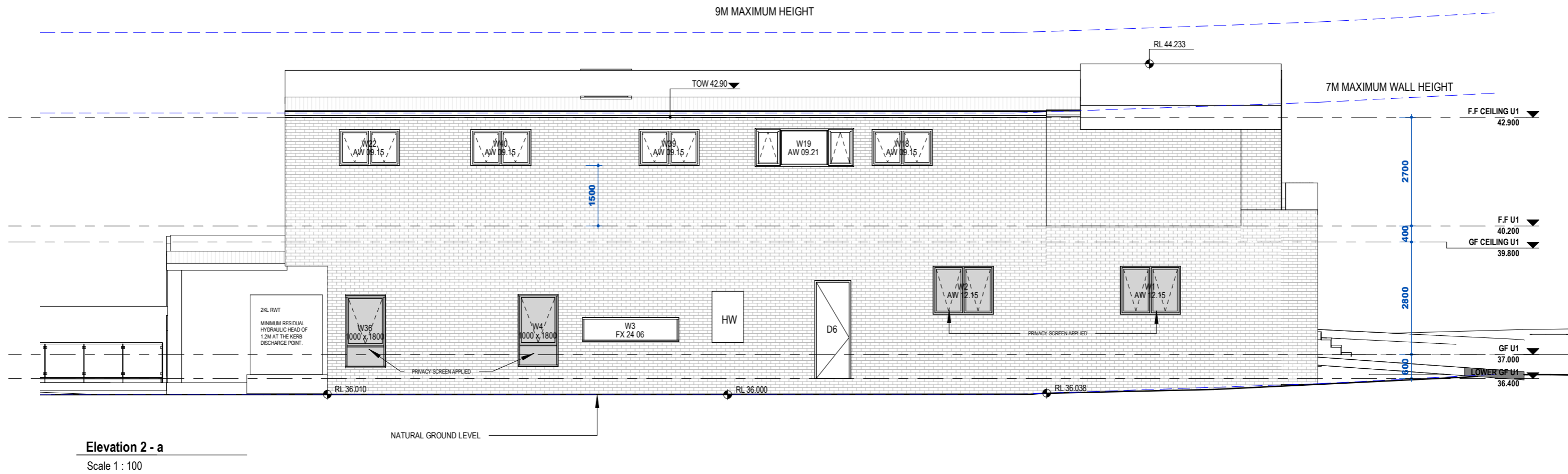
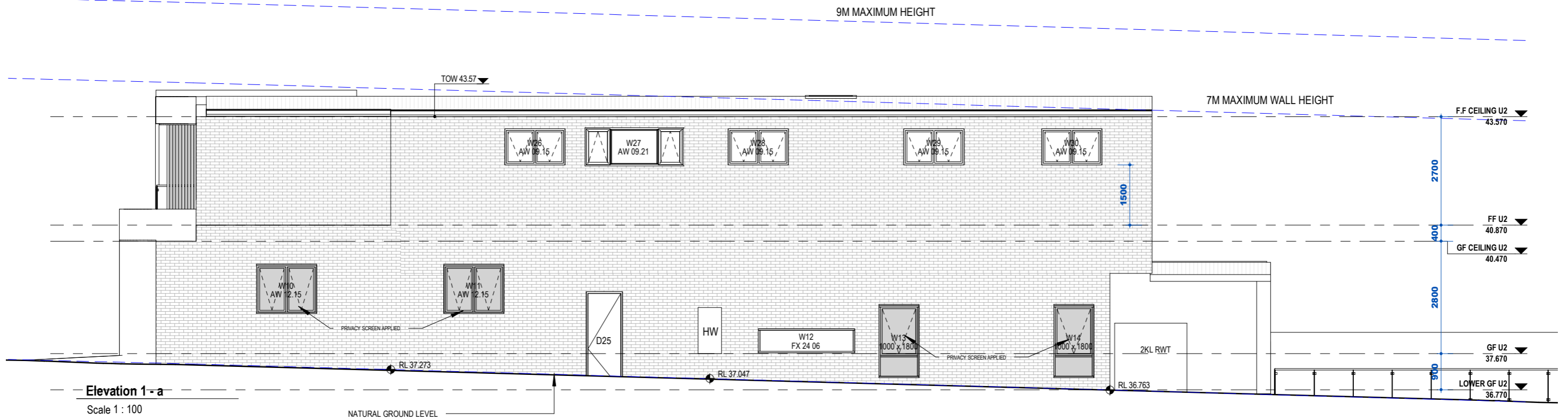

52 Hall Street, Bondi Beach, NSW, 2026
 info@mjhomes.com.au
 0456 888 444



<p>© COPYRIGHT</p> <p>THIS DOCUMENT IS SUBJECT TO COPYRIGHT LAWS & MAY NOT BE COPIED IN PART OF WHOLE WITHOUT THE WRITTEN PERMISSION OF JMJ HOMES PTY LTD</p>	<p>NOTES:</p> <ol style="list-style-type: none"> 1. ALL DIMENSIONS AND FLOOR AREAS TO BE VERIFIED PRIOR TO THE COMMENCEMENT OF ANY BUILDING WORK. 2. ANY DISCREPANCIES ARE TO BE CONFIRMED BY THE DESIGNER. 3. LEVELS SHOWN ARE APPROXIMATE UNLESS ACCOMPANIED BY REDUCED LEVELS BY A REGISTERED SURVEYOR. 4. FIGURED DIMENSIONS ARE TO BE TAKEN IN PREFERENCE TO SCALING. 5. ALL BOUNDARY CLEARANCE MUST BE VERIFIED BY THE SURVEYOR PRIOR TO THE COMMENCEMENT OF ANY BUILDING WORK. 6. WHERE ENGINEERING OR HYDRAULIC DRAWINGS ARE REQUIRED, SUCH MUST TAKE PREFERENCE TO THIS DRAWINGS. 7. ALL SERVICES TO BE LOCATED AND VERIFIED BY THE BUILDER PRIOR TO THE COMMENCEMENT OF ANY BUILDING WORK. 	<p>Issued for: DA</p> <p>Designed by: S.L</p> <p>Drawn by: S.L</p> <p>Checked by: R.B</p> <p>Issued Date: 25/11/24</p>	 <p>TRUE NORTH</p>	<p>Drawing Title</p> <p>008</p> <p>ELEVATION 2</p> <p>SCALE@A3 1 : 100</p>	<p>PROJECT TITLE:</p> <p>29 Queensbury Road Padstow</p> <p>Height</p> <p>CLIENTS:</p>	 <p>52 Hall Street, Bondi Beach, NSW, 2026</p> <p>info@mjhomes.com.au</p> <p>0456 888 444</p>
---	--	--	---	--	---	--

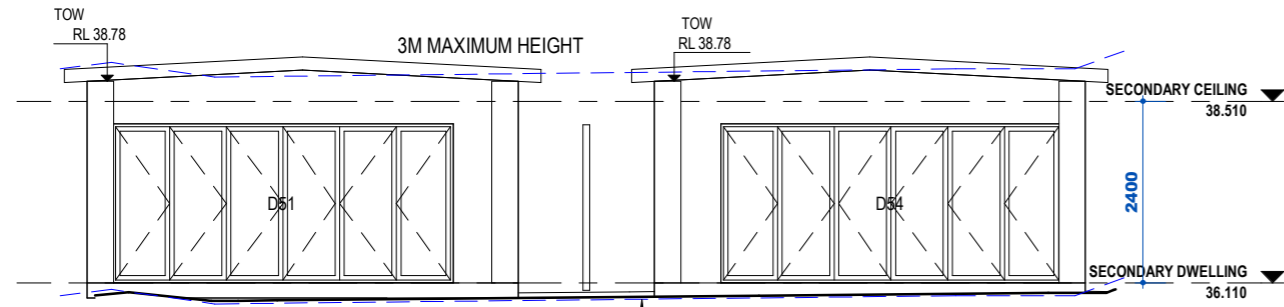

SECONDARY DWELLING WEST ELEVATION

Scale 1 : 100

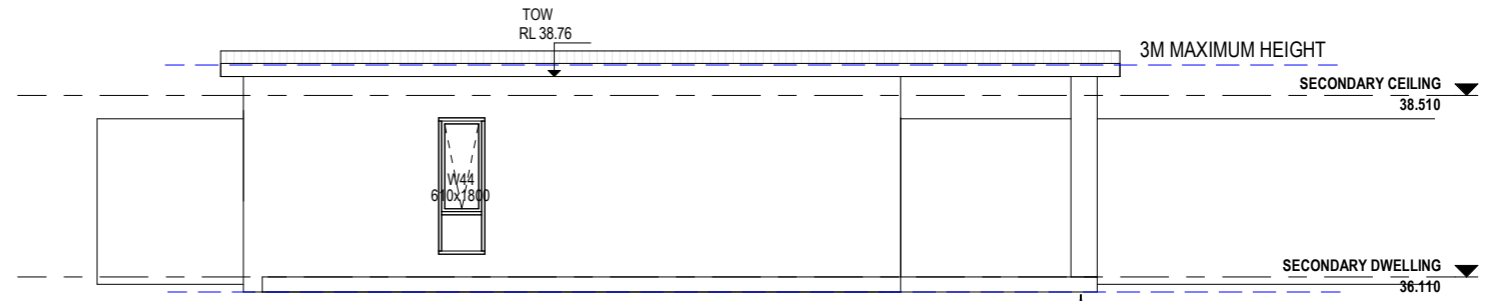

SECONDARY DWELLING LOT 1 NORTH ELEVATION

Scale 1 : 100

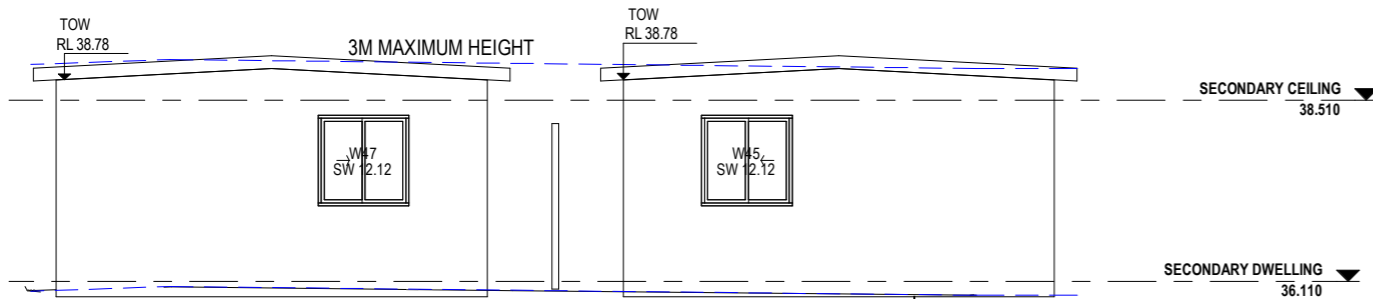

SECONDARY DWELLING EAST ELEVATION

Scale 1 : 100

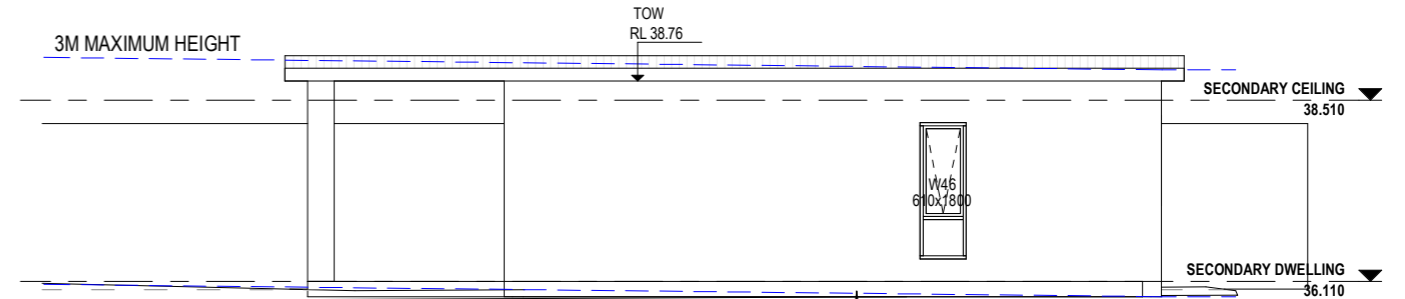

SECONDARY DWELLING LOT 2 SOUTH ELEVATION

Scale 1 : 100

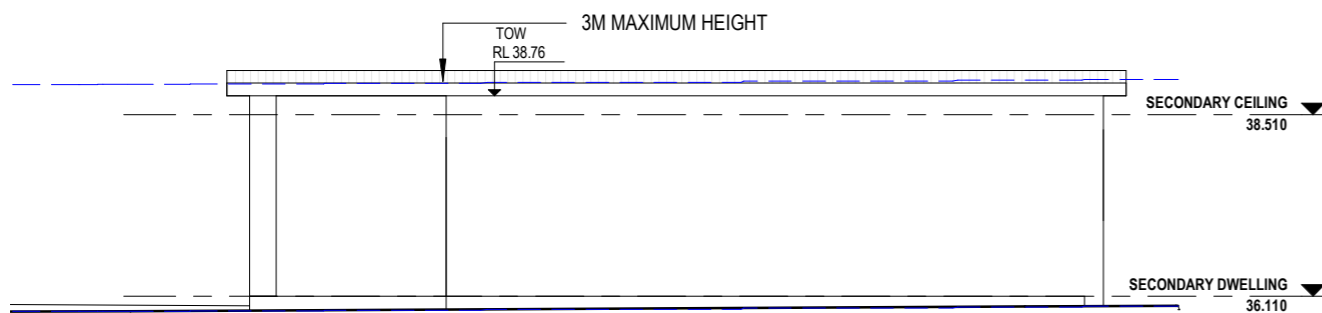

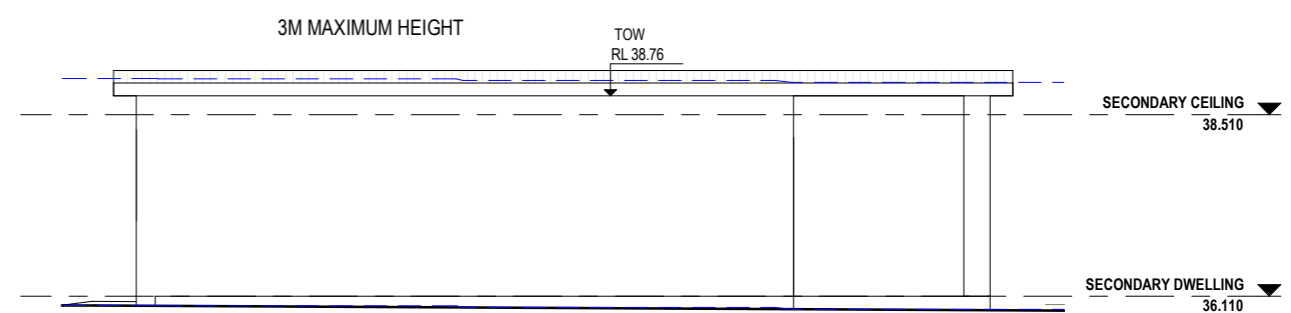

SECONDARY DWELLING LOT 1 SOUTH ELEVATION

Scale 1 : 100



SECONDARY DWELLING LOT 2 NORTH ELEVATION

Scale 1 : 100

<p>© COPYRIGHT</p> <p>THIS DOCUMENT IS SUBJECT TO COPYRIGHT LAWS & MAY NOT BE COPIED IN PART OF WHOLE WITHOUT THE WRITTEN PERMISSION OF JMJ HOMES PTY LTD</p>	<p>NOTES:</p> <ol style="list-style-type: none"> 1. ALL DIMENSIONS AND FLOOR AREAS TO BE VERIFIED PRIOR TO THE COMMENCEMENT OF ANY BUILDING WORK. 2. ANY DISCREPANCIES ARE TO BE CONFIRMED BY THE DESIGNER. 3. LEVELS SHOWN ARE APPROXIMATE UNLESS ACCOMPANIED BY REDUCED LEVELS BY A REGISTERED SURVEYOR. 4. FIGURED DIMENSIONS ARE TO BE TAKEN IN PREFERENCE TO SCALING. 5. ALL BOUNDARY CLEARANCE MUST BE VERIFIED BY THE SURVEYOR PRIOR TO THE COMMENCEMENT OF ANY BUILDING WORK. 6. WHERE ENGINEERING OR HYDRAULIC DRAWINGS ARE REQUIRED, SUCH MUST TAKE PREFERENCE TO THIS DRAWINGS. 7. ALL SERVICES TO BE LOCATED AND VERIFIED BY THE BUILDER PRIOR TO THE COMMENCEMENT OF ANY BUILDING WORK. 	<p>Issued for: DA</p> <p>Designed by: S.L</p> <p>Drawn by: S.L</p> <p>Checked by: R.B</p> <p>Issued Date: 25/11/24</p>	<p></p> <p>TRUE NORTH</p>	<p>Drawing Title</p> <p>009</p> <p>ELEVATION 3</p> <p>SCALE@A3 1 : 100</p>	<p>PROJECT TITLE:</p> <p>29 Queensbury Road Padstow</p> <p>Height</p> <p>CLIENTS:</p>	<p></p> <p>52 Hall Street, Bondi Beach, NSW, 2026</p> <p>info@mjhomes.com.au</p> <p>0456 888 444</p>
---	--	--	--	--	---	---

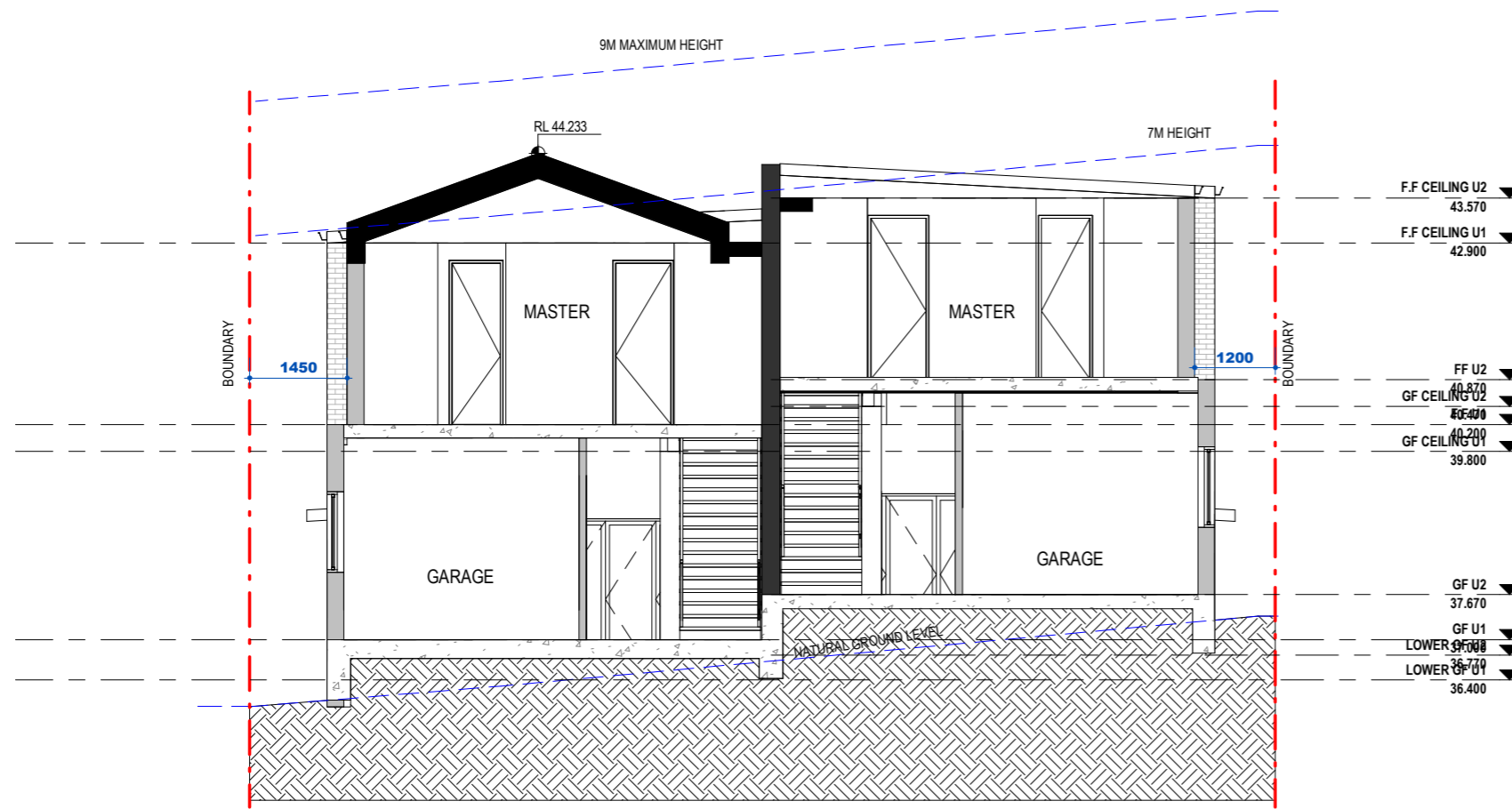

Section 7

Scale 1 : 100

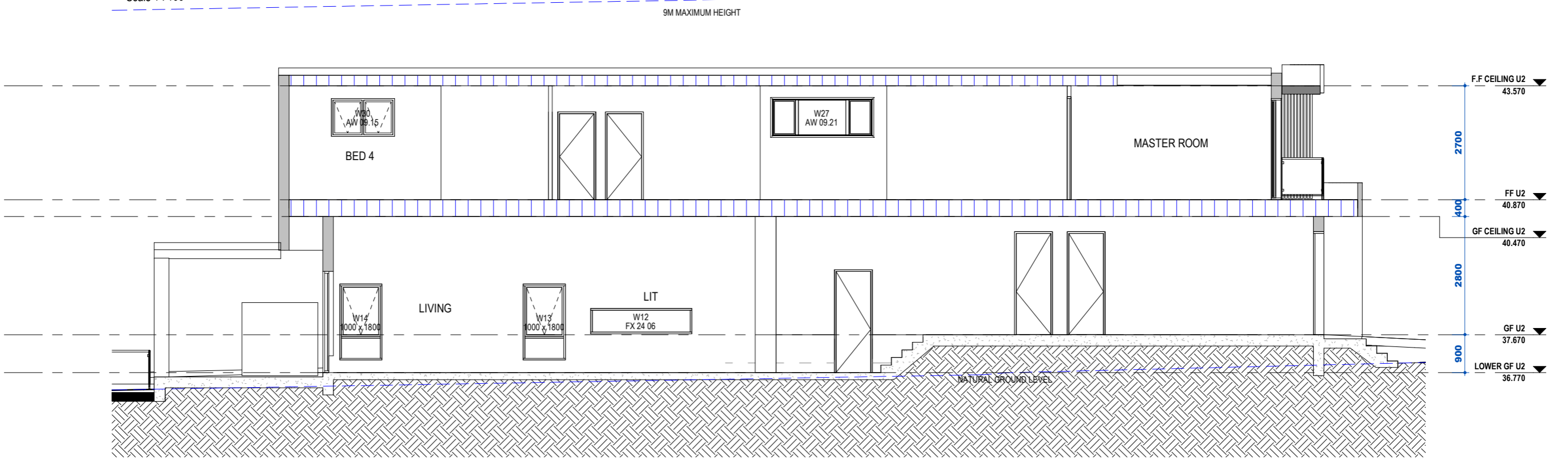

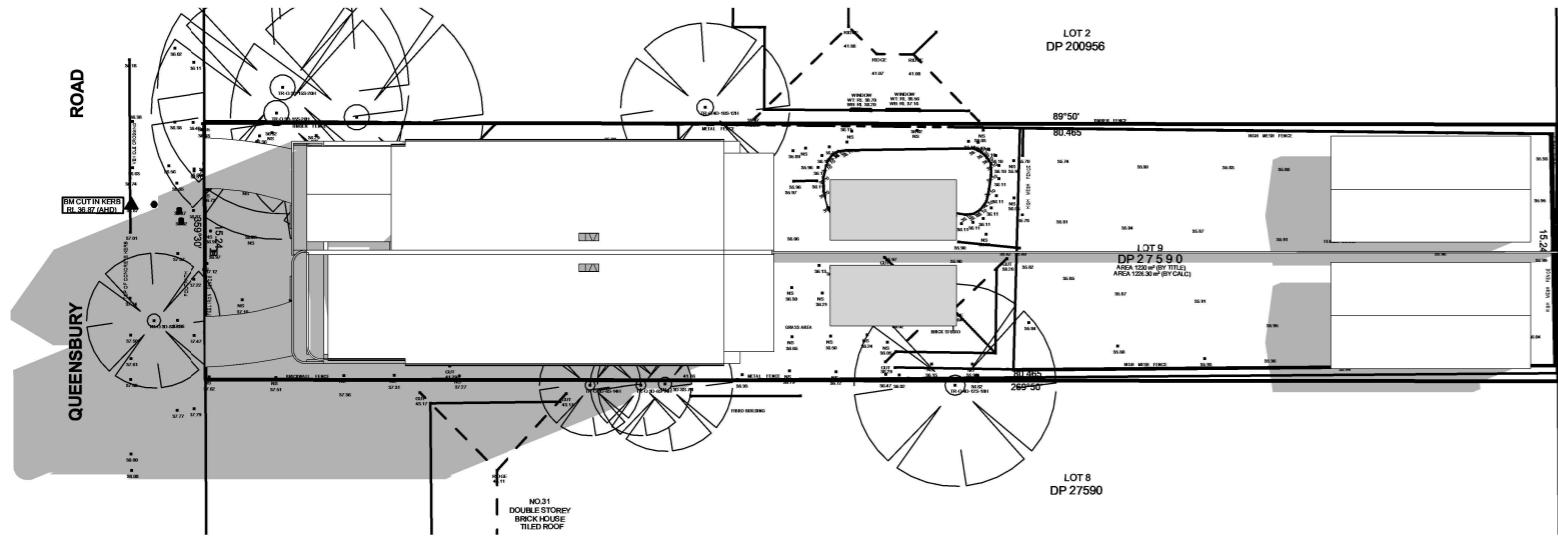

SHADOW DIAGRAM - 09am, 21 June

Scale1 : 450

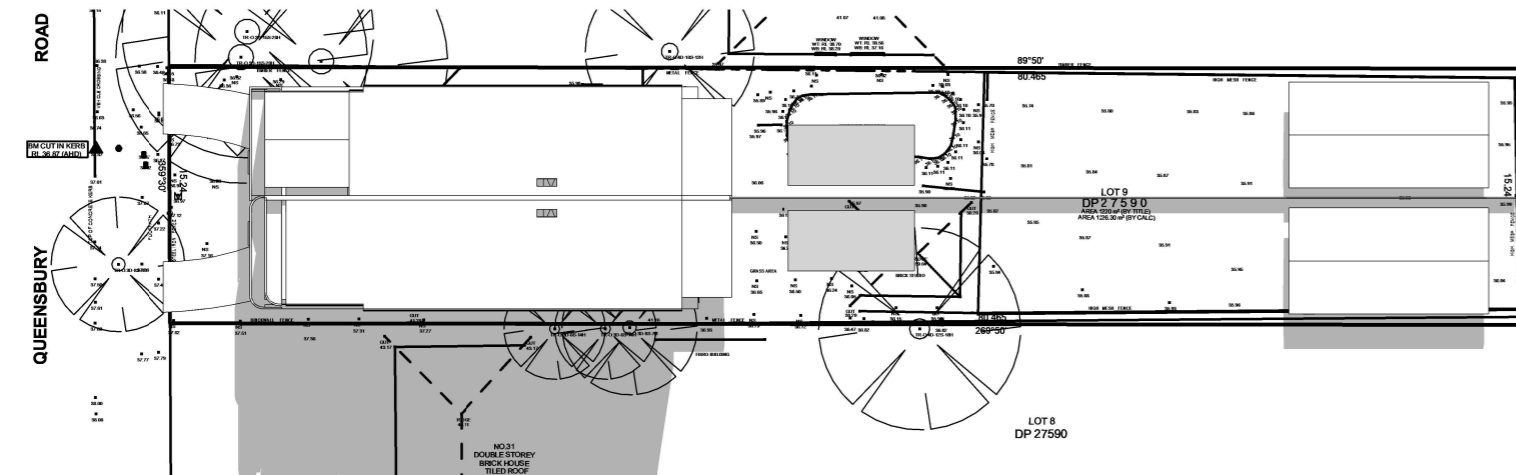

SHADOW DIAGRAM - 12pm, 21 June

Scale1 : 450

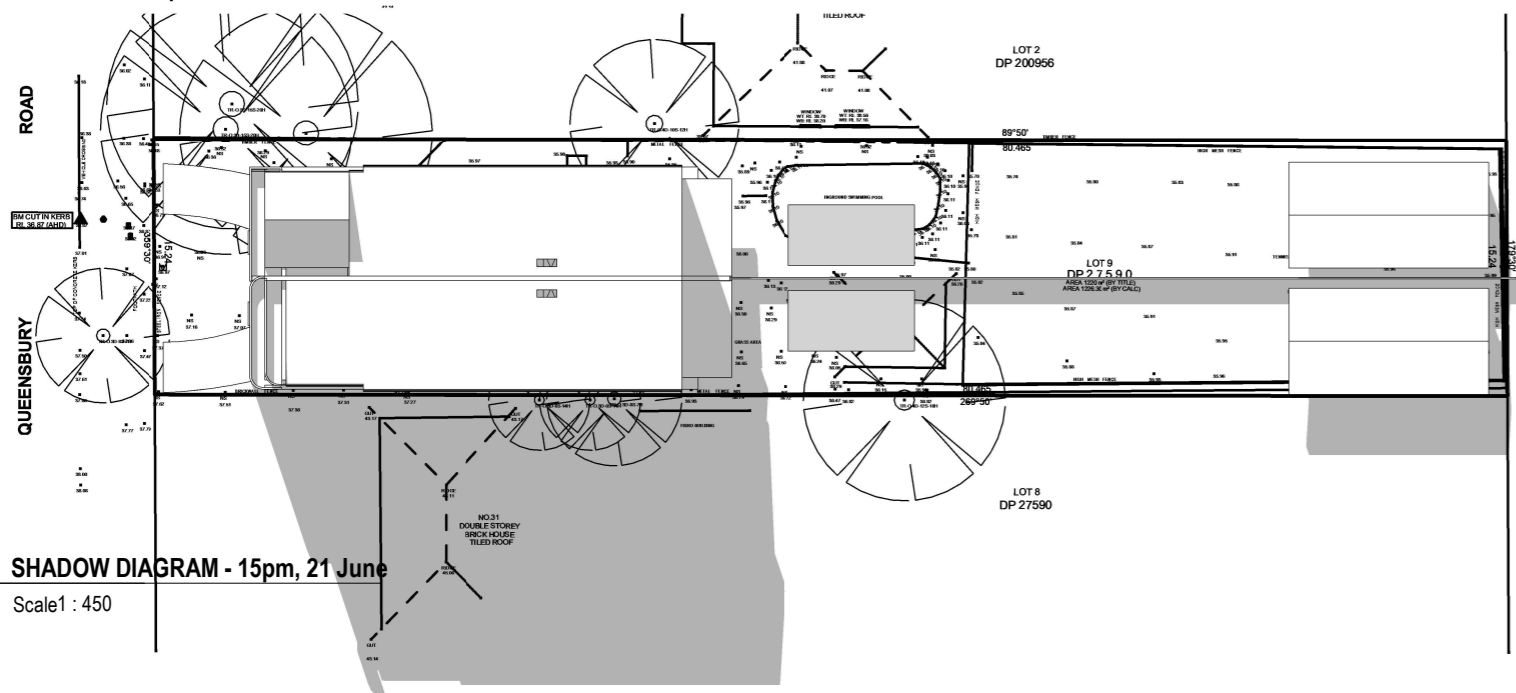

SHADOW DIAGRAM - 15pm, 21 June

Scale1 : 450

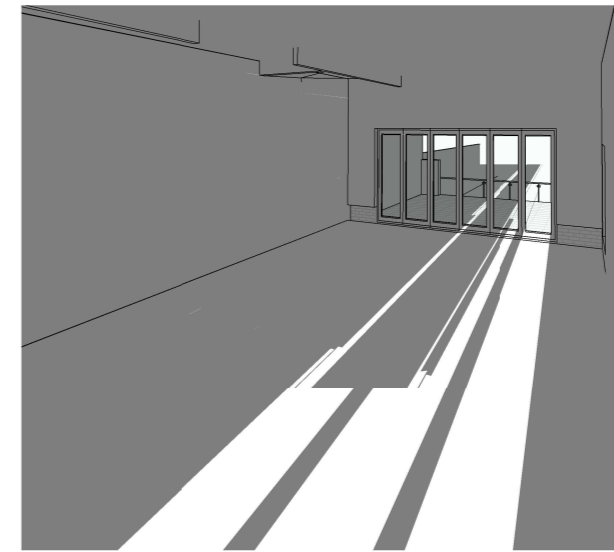

SOUTH LIVING SHADOW DIAGRAM - 8am, 21 June

Scale

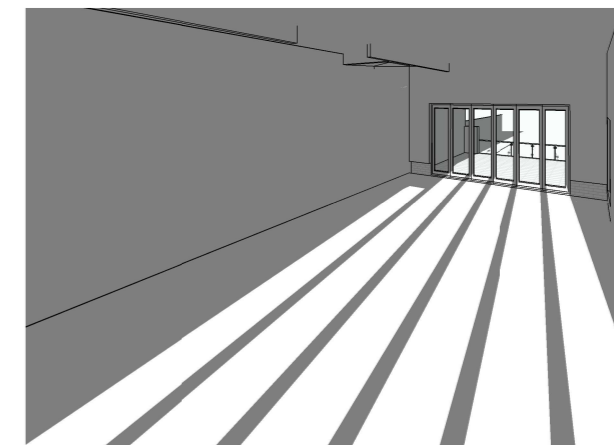

SOUTH LIVING SHADOW DIAGRAM - 9am, 21 June

Scale

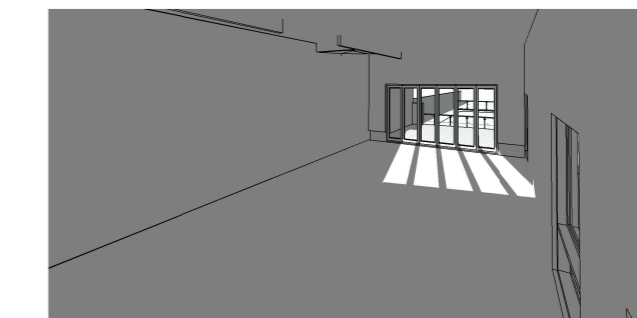

SOUTH LIVING SHADOW DIAGRAM - 10am, 21 June

Scale

© COPYRIGHT

THIS DOCUMENT IS SUBJECT TO COPYRIGHT LAWS & MAY NOT BE COPIED IN PART OF WHOLE WITHOUT THE WRITTEN PERMISSION OF JMJ HOMES PTY LTD

NOTES:

1. ALL DIMENSIONS AND FLOOR AREAS TO BE VERIFIED PRIOR TO THE COMMENCEMENT OF ANY BUILDING WORK.
2. ANY DISCREPANCIES ARE TO BE CONFIRMED BY THE DESIGNER.
3. LEVELS SHOWN ARE APPROXIMATE UNLESS ACCOMPANIED BY REDUCED LEVELS BY A REGISTERED SURVEYOR.
4. FIGURED DIMENSIONS ARE TO BE TAKEN IN PREFERENCE TO SCALING.
5. ALL BOUNDARY CLEARANCE MUST BE VERIFIED BY THE SURVEYOR PRIOR TO THE COMMENCEMENT OF ANY BUILDING WORK.
6. WHERE ENGINEERING OR HYDRAULIC DRAWINGS ARE REQUIRED, SUCH MUST TAKE PREFERENCE TO THIS DRAWINGS.
7. ALL SERVICES TO BE LOCATED AND VERIFIED BY THE BUILDER PRIOR TO THE COMMENCEMENT OF ANY BUILDING WORK.

Issued for: DA
 Designed by: S.L
 Drawn by: S.L
 Checked by: R.B
 Issued Date: 25/11/24



Drawing Title
011
SHADOW DIAGRAM

SCALE@A3 1 : 450

PROJECT TITLE:

29 Queensbury Road Padstow Height

CLIENTS:



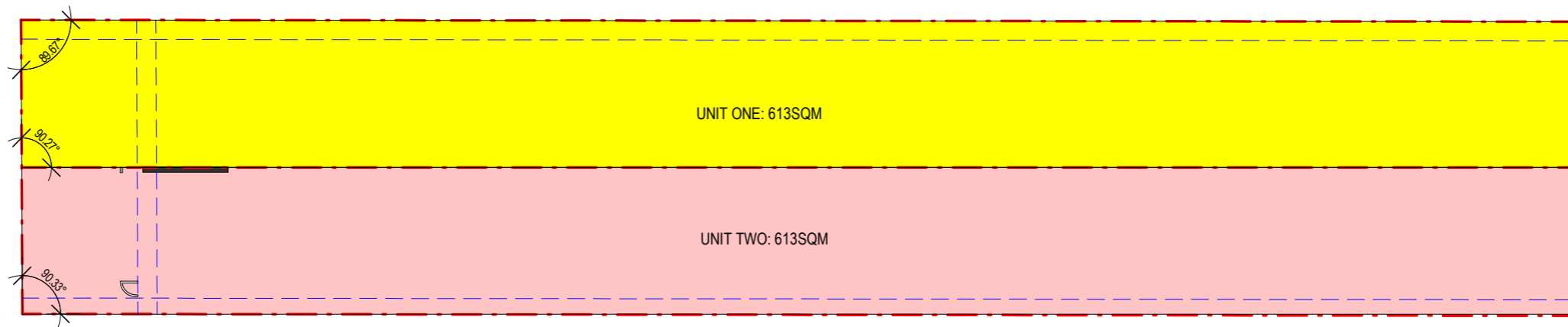

52 Hall Street, Bondi Beach, NSW, 2026
 info@mjhomes.com.au
 0456 888 444



SUBDIVISION PLAN

Scale 1 : 300

<p>© COPYRIGHT</p> <p>THIS DOCUMENT IS SUBJECT TO COPYRIGHT LAWS & MAY NOT BE COPIED IN PART OF WHOLE WITHOUT THE WRITTEN PERMISSION OF JMJ HOMES PTY LTD</p>	<p>NOTES:</p> <ol style="list-style-type: none"> 1. ALL DIMENSIONS AND FLOOR AREAS TO BE VERIFIED PRIOR TO THE COMMENCEMENT OF ANY BUILDING WORK. 2. ANY DISCREPANCIES ARE TO BE CONFIRMED BY THE DESIGNER. 3. LEVELS SHOWN ARE APPROXIMATE UNLESS ACCOMPANIED BY REDUCED LEVELS BY A REGISTERED SURVEYOR. 4. FIGURED DIMENSIONS ARE TO BE TAKEN IN PREFERENCE TO SCALING. 5. ALL BOUNDARY CLEARANCE MUST BE VERIFIED BY THE SURVEYOR PRIOR TO THE COMMENCEMENT OF ANY BUILDING WORK. 6. WHERE ENGINEERING OR HYDRAULIC DRAWINGS ARE REQUIRED, SUCH MUST TAKE PREFERENCE TO THIS DRAWINGS. 7. ALL SERVICES TO BE LOCATED AND VERIFIED BY THE BUILDER PRIOR TO THE COMMENCEMENT OF ANY BUILDING WORK. 	<p>Issued for: DA</p> <p>Designed by: S.L</p> <p>Drawn by: S.L</p> <p>Checked by: R.B</p> <p>Issued Date: 25/11/24</p>	<p>TRUE NORTH</p> 	<p>Drawing Title</p> <p>012</p> <p>SUBDIVISION PLAN</p> <p>SCALE@A3 1 : 300</p>	<p>PROJECT TITLE:</p> <p>29 Queensbury Road Padstow</p> <p>Height</p> <p>CLIENTS:</p>	 <p>52 Hall Street, Bondi Beach, NSW, 2026</p> <p>info@mjhomes.com.au</p> <p>0456 888 444</p>
---	--	--	---	---	---	--

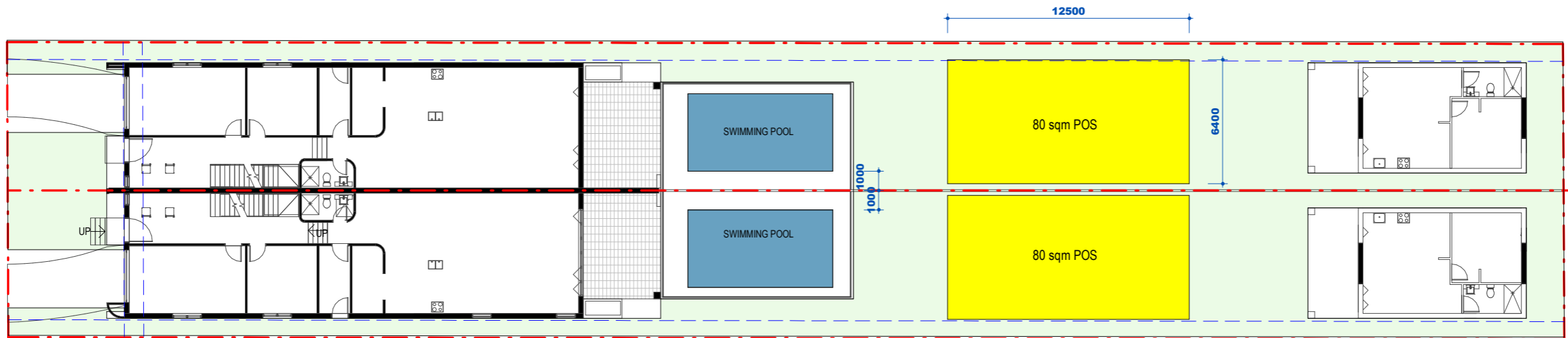

SEDIMENT CONTROL PLAN

Scale1 : 250

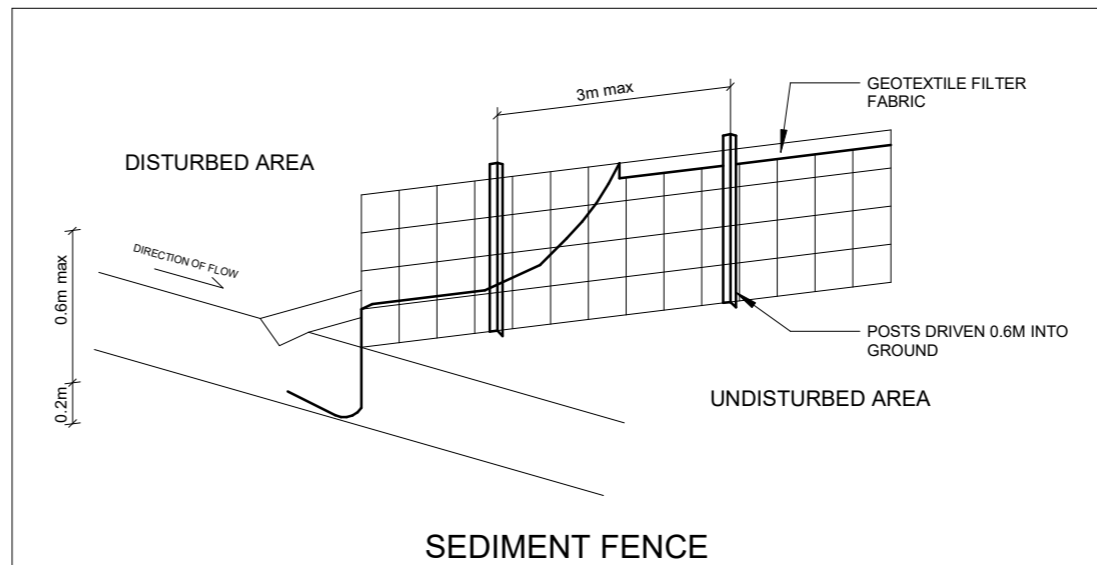
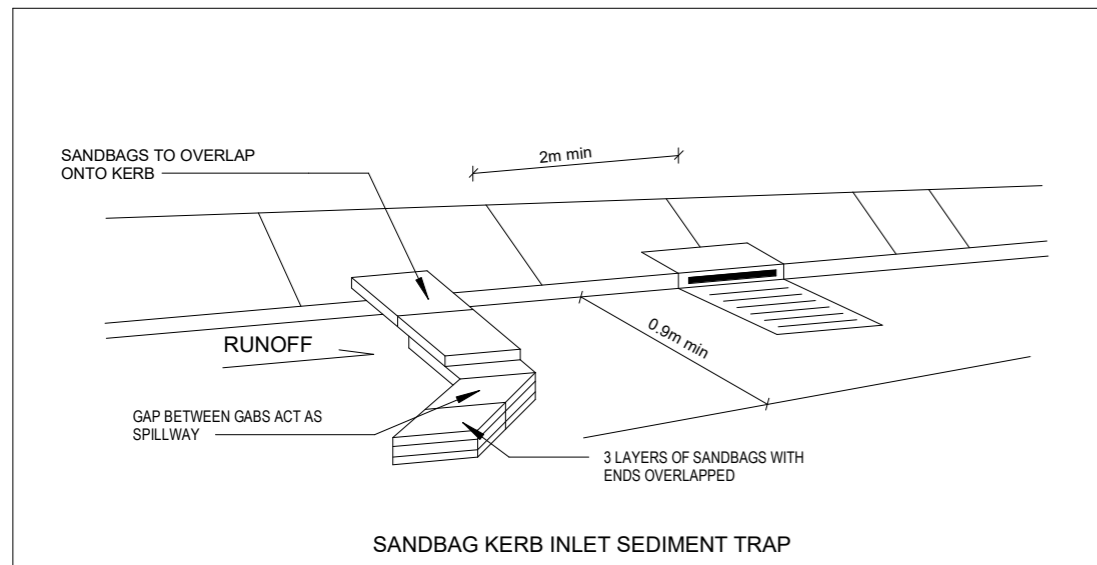

SEDIMENT CONTROL NOTES:

ALL EROSION & SEDIMENT CONTROL MEASUREMENTS INCLUDING:

REVEGETATION AND STORAGE OF SOIL & TOP SOIL, SHALL BE IMPLEMENTED TO THE STANDARD OF THE SOIL CONSERVATION OF NSW.

ALL DRAINAGE WORKS SHALL BE CONSTRUCTED AROUND AND STABILIZED AS EARLY AS POSSIBLE DURING DEVELOPMENT.

SEDIMENT TRAPS SHALL BE CONSTRUCTED AROUND ALL INLET PITS, CONSISTING OF 300MM WIDE X 300MM DEEP TRENCHES.

ALL SEDIMENT BASINS & TRAPS SHALL BE CLEARED WHEN THE STRUCTURES ARE A MAXIMUM OF 60% FULL OF MATERIALS, INCLUDING THE MAINTENANCE PERIOD.

ALL DISTURBED AREAS SHALL BE REVEGETATED AS SOON AS THE RELEVANT WORKS ARE COMPLETED.

SOIL & TOPSOIL STOCKPILES SHALL BE LOCATED AWAY FROM DRAINAGE LINES AND AREA WATER MAY CONCENTRATE.

FILTERS SHALL BE CONSTRUCTED BY STRETCHING A FILTER FABRIC (PROPEX OR APPROVED EQUIVALENT BETWEEN POST AS 2M CENTRES).

FABRIC SHALL BE BURIED 150MM ALONG ITS LOWER EDGE.

Window Schedule		
Mark	Width	Height

W1	1500	1200
W2	1500	1200
W3	2400	600
W4	1000	1800
W6	600	2400
W9	600	2400
W10	1500	1200
W11	1500	1200
W12	2400	600
W13	1000	1800
W14	1000	1800
W17	4000	2400
W18	1500	900
W19	2400	900
W22	1500	900
W26	1500	900
W27	2400	900
W28	1500	900
W29	1500	900
W30	1500	900
W32	CUSTOMIZED	
W35	450	1190
W36	1000	1800
W37	CUSTOMIZED	
W38	450	1190
W39	1500	900
W40	1500	900
W41	610	1800
W43	610	1800
W44	610	1800
W45	1200	1200
W46	610	1800
W47	1200	1200
W50	4000	2400

Door Schedule		
Mark	Width	Height

D1	1200	2400
D2	2700	2400
D3	820	2400
D4	820	2400
D5	820	2400
D6	820	2400
D6	720	2400
D12	820	2400
D13	720	2400
D19	1200	2400
D20	2700	2400
D21	820	2400
D22	820	2400
D23	720	2400
D24	820	2400
D25	820	2400
D30	820	2400
D31	720	2400
D37	4500	2400
D38	4500	2400
D40	820	2040
D41	820	2040
D42	820	2040
D43	720	2400
D44	720	2400
D45	820	2040
D46	820	2040
D47	820	2040
D48	720	2400
D49	720	2400
D50	820	2040
D51	4500	2100
D52	820	2040
D53	820	2040
D54	4500	2100
D55	820	2040

© COPYRIGHT

THIS DOCUMENT IS SUBJECT TO COPYRIGHT LAWS & MAY NOT BE COPIED IN PART OR WHOLE WITHOUT THE WRITTEN PERMISSION OF JMJ HOMES PTY LTD

NOTES:

1. ALL DIMENSIONS AND FLOOR AREAS TO BE VERIFIED PRIOR TO THE COMMENCEMENT OF ANY BUILDING WORK.
2. ANY DISCREPANCIES ARE TO BE CONFIRMED BY THE DESIGNER.
3. LEVELS SHOWN ARE APPROXIMATE UNLESS ACCOMPANIED BY REDUCED LEVELS BY A REGISTERED SURVEYOR.
4. FIGURED DIMENSIONS ARE TO BE TAKEN IN PREFERENCE TO SCALING.
5. ALL BOUNDARY CLEARANCE MUST BE VERIFIED BY THE SURVEYOR PRIOR TO THE COMMENCEMENT OF ANY BUILDING WORK.
6. WHERE ENGINEERING OR HYDRAULIC DRAWINGS ARE REQUIRED, SUCH MUST TAKE PREFERENCE TO THIS DRAWINGS.
7. ALL SERVICES TO BE LOCATED AND VERIFIED BY THE BUILDER PRIOR TO THE COMMENCEMENT OF ANY BUILDING WORK.

Issued for: DA
 Designed by: S.L
 Drawn by: S.L
 Checked by: R.B
 Issued Date: 25/11/24



TRUE NORTH

Drawing Title

014
WINDOW/DOOR SCHEDULE

SCALE@A3

PROJECT TITLE:

29 Queensbury Road Padstow
Height

CLIENTS:



52 Hall Street, Bondi Beach, NSW, 2026

info@mjhomes.com.au

0456 888 444

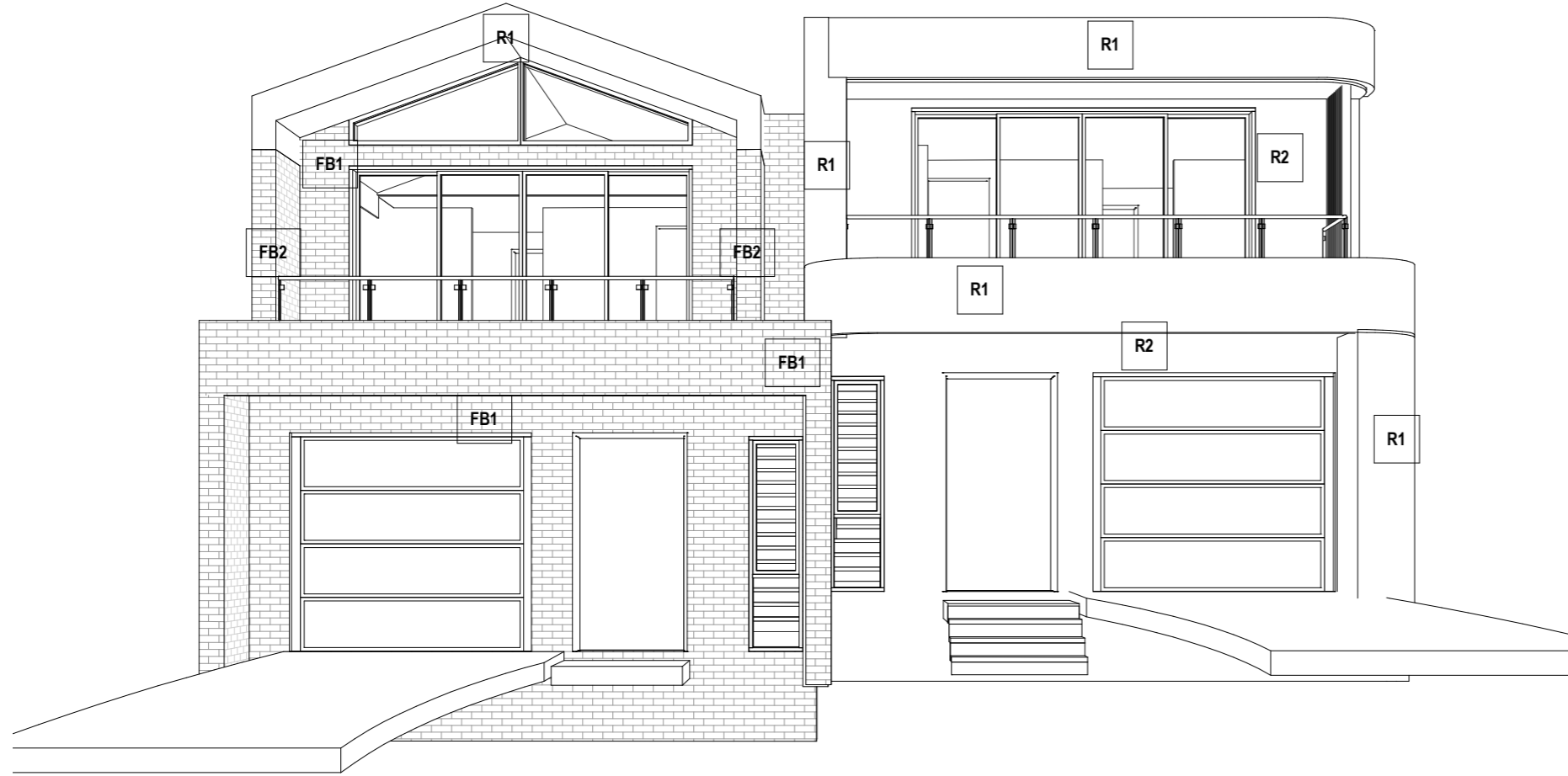

EXTERNAL FINISH SCHEDULE		
ITEM	DESCRIPTION	REFERENCE
EXTERNAL BRICK WALL: FB1 PGH BRICKS	WHITE OR SIMILAR	
EXTERNAL BRICK WALL: FB2 PGH BRICKS	GREY OR SIMILAR	
FEATURE RENDER: R1	CONCRETE RENDER	
FEATURE RENDER: R2	BRICK RENDER - WHITE	
ROOF COVERING: TR COLORBOND ROOF	LIGHT GREY OR SIMILAR	
GARAGE DOOR: PANEL LIFT GARAGE DOOR	TIMBER PANEL OR SIMILAR	
WINDOW & SLIDING DOOR : ALUMINIUM FRAME	BLACK OR SIMILAR	
GUTTER, FASCIA & DOWNPIPES: COLORBOND	MONUMENT OR SIMILAR	
FRONT DOOR: HUME PAINTED TIMBER	TIMBER LOOK OR SIMILAR	
DRIVEWAY: COLORED CONCRETE DRIVEWAY	GREY	
GLASS & BALUSTRADE: CLEAR GLASS & BALUSTRADE WITH SPIGOT	CHROME CAPPING & SPIGOT	

© COPYRIGHT

THIS DOCUMENT IS SUBJECT TO COPYRIGHT LAWS & MAY NOT BE COPIED IN PART OF WHOLE WITHOUT THE WRITTEN PERMISSION OF JMJ HOMES PTY LTD

NOTES:

1. ALL DIMENSIONS AND FLOOR AREAS TO BE VERIFIED PRIOR TO THE COMMENCEMENT OF ANY BUILDING WORK.
2. ANY DISCREPANCIES ARE TO BE CONFIRMED BY THE DESIGNER.
3. LEVELS SHOWN ARE APPROXIMATE UNLESS ACCOMPANIED BY REDUCED LEVELS BY A REGISTERED SURVEYOR.
4. FIGURED DIMENSIONS ARE TO BE TAKEN IN PREFERENCE TO SCALING.
5. ALL BOUNDARY CLEARANCE MUST BE VERIFIED BY THE SURVEYOR PRIOR TO THE COMMENCEMENT OF ANY BUILDING WORK.
6. WHERE ENGINEERING OR HYDRAULIC DRAWINGS ARE REQUIRED, SUCH MUST TAKE PREFERENCE TO THIS DRAWINGS.
7. ALL SERVICES TO BE LOCATED AND VERIFIED BY THE BUILDER PRIOR TO THE COMMENCEMENT OF ANY BUILDING WORK.

Issued for: DA
Designed by: S.L
Drawn by: S.L
Checked by: R.B
Issued Date: 25/11/24



Drawing Title
015
MATERIAL FINISH
SCALE@A3 1 : 100

PROJECT TITLE:
29 Queensbury Road Padstow
Height
CLIENTS:



52 Hall Street, Bondi Beach, NSW, 2026
info@jmjhomes.com.au
0456 888 444

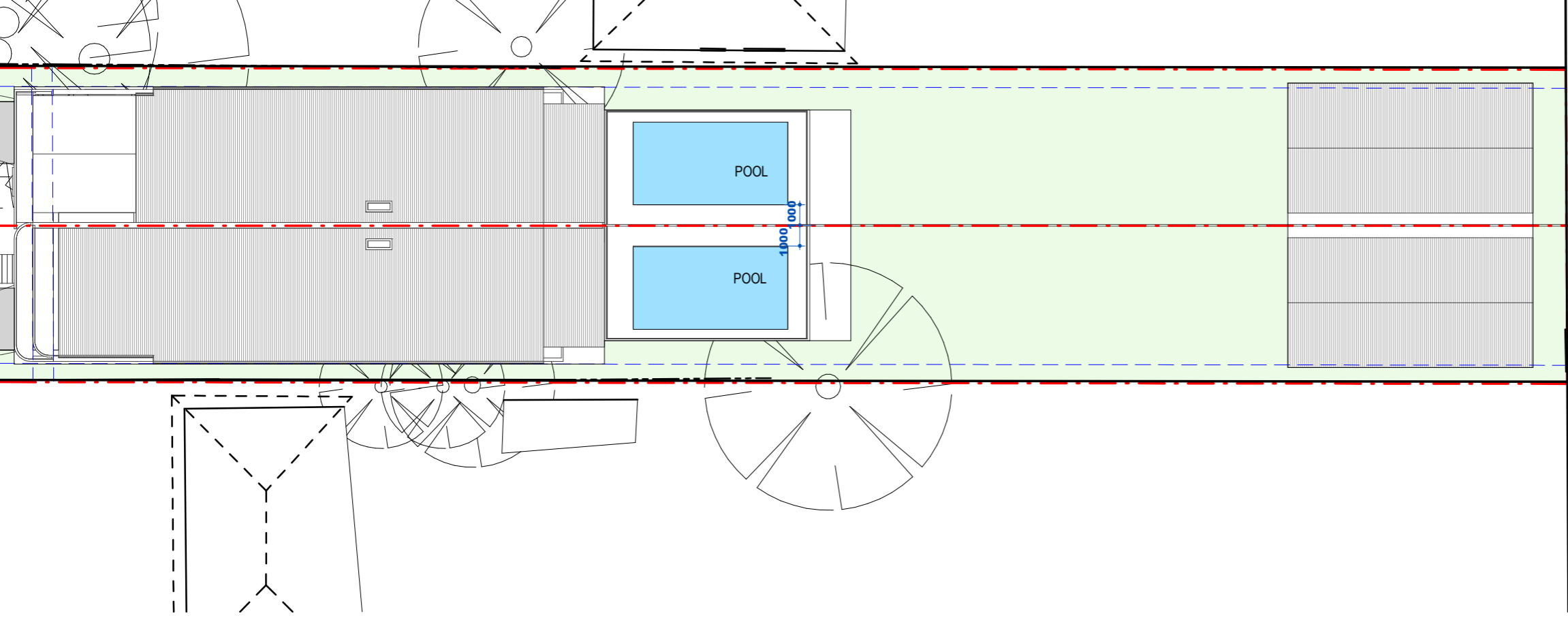

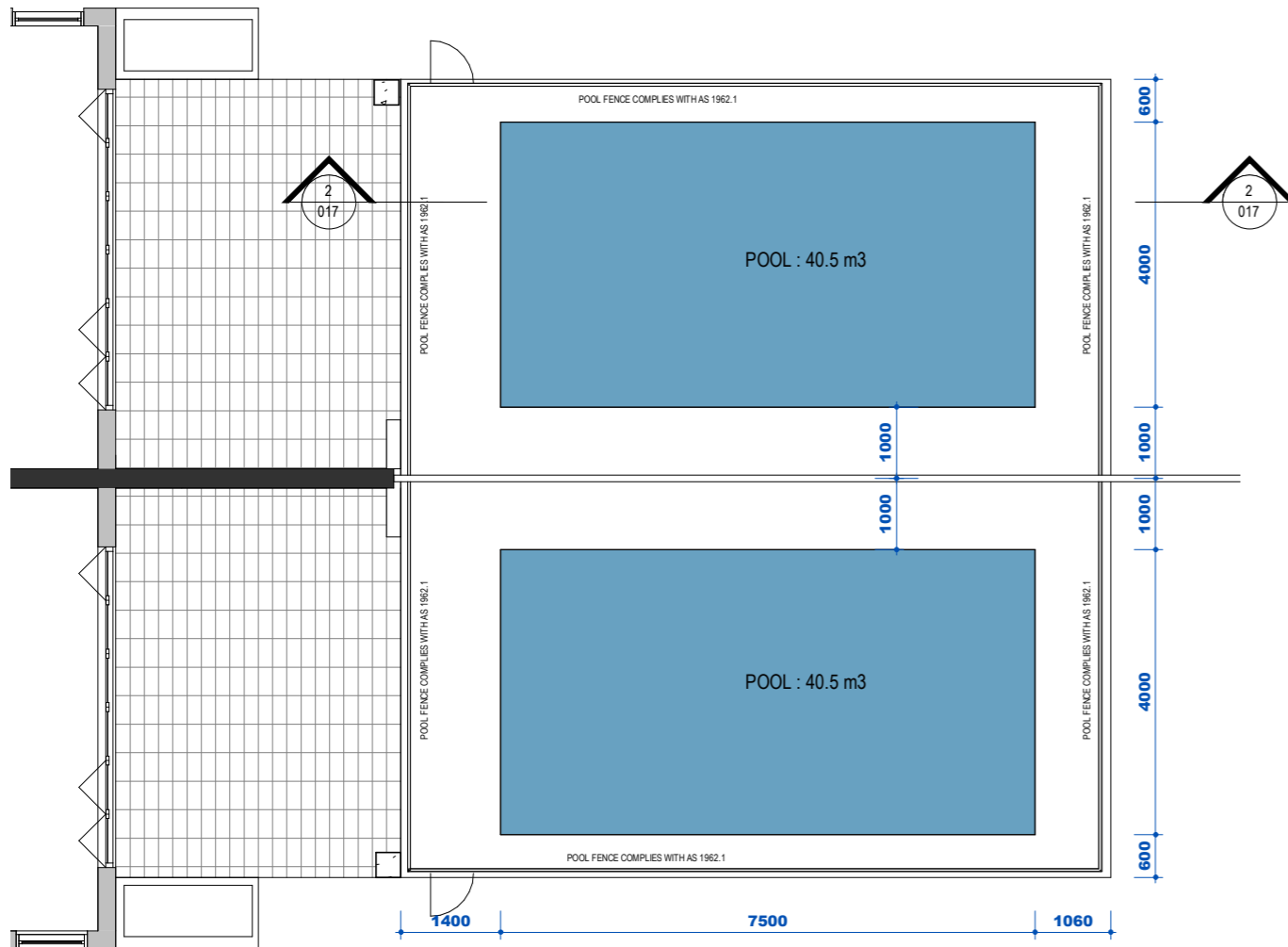

POOL PROFILE

Scale 1 : 100

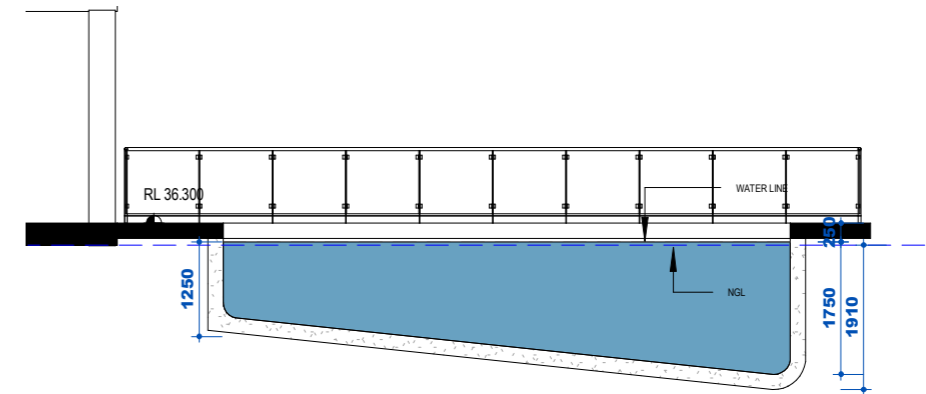

POOL SECTION

Scale 1 : 100

<p>© COPYRIGHT THIS DOCUMENT IS SUBJECT TO COPYRIGHT LAWS & MAY NOT BE COPIED IN PART OF WHOLE WITHOUT THE WRITTEN PERMISSION OF JMJ HOMES PTY LTD</p>	<p>NOTES: 1. ALL DIMENSIONS AND FLOOR AREAS TO BE VERIFIED PRIOR TO THE COMMENCEMENT OF ANY BUILDING WORK. 2. ANY DISCREPANCIES ARE TO BE CONFIRMED BY THE DESIGNER. 3. LEVELS SHOWN ARE APPROXIMATE UNLESS ACCOMPANIED BY REDUCED LEVELS BY A REGISTERED SURVEYOR. 4. FIGURED DIMENSIONS ARE TO BE TAKEN IN PREFERENCE TO SCALING. 5. ALL BOUNDARY CLEARANCE MUST BE VERIFIED BY THE SURVEYOR PRIOR TO THE COMMENCEMENT OF ANY BUILDING WORK. 6. WHERE ENGINEERING OR HYDRAULIC DRAWINGS ARE REQUIRED, SUCH MUST TAKE PREFERENCE TO THIS DRAWINGS. 7. ALL SERVICES TO BE LOCATED AND VERIFIED BY THE BUILDER PRIOR TO THE COMMENCEMENT OF ANY BUILDING WORK.</p>	<p>Issued for: DA Designed by: S.L Drawn by: S.L Checked by: R.B Issued Date: 25/11/24</p>	<p>TRUE NORTH</p>	<p>Drawing Title 017 POOL PROFILE SCALE@A3 1 : 100</p>	<p>PROJECT TITLE: 29 Queensbury Road Padstow Height CLIENTS:</p>	<p>JMJ HOMES 52 Hall Street, Bondi Beach, NSW, 2026 info@mjhomes.com.au 0456 888 444</p>
--	--	--	-------------------	--	--	---